

Mounting Application Notes

Mounting of High Power Flange Devices

When mounting High Power Flange Devices in a circuit, there are several key issues that should be taken into account.

Heat Sink Design

The heat sink the device is mounted to must be designed to maintain the temperature (design) while it is dissipating the power (heat) given it by the device. (The derating specifications are given in the applicable data sheets.)

Flatness of mating surfaces

Flatness of the heat sink and of the mounting area of the device (flange) should be 0.001" maximum. The idea is to have the best possible contact between the heat sink and the device.

Thermal Compound

To fill any microscopic voids or air gaps the use of thermal compound is recommended to a thickness of 0.002" maximum.

Stress Relief on Tab

Although it is not always possible in High Frequency applications a small loop for stress relief on the solder tab is recommended. This reduces any mechanical stress on the joints.

Apply a small amount of thermal compound to the mounting area of the flange of the device. Spread it completely on the flange using a razor blade or other smooth tool. When seating the device, align the tab/tabs over the corresponding area on the circuit board. Screw down the device using the recommended torque for the appropriate screw size in the table below. Aeroflex / Inmet recommends the use of a lock washer and a flat washer in the installation. See Figure 1

Thread Size	Torque Setting
2-56	4 inch-pounds
4-40	6 inch pounds
6-32	8 inch pounds
8-32	12 inch pounds
10-32	18 inch pounds

Solder the tab/tabs using SN63 (179° C eutectic) solder and a small amount of RMA flux. After all the solder is complete all of the flux must now be removed using a cleaning agent.

Mounting of Chip Devices

This application note covers the recommended mounting techniques for the proper conduction cooling and RF performance of a surface mounted (flangeless) chip attenuator, termination or resistor.

Initial Considerations

There are two primary considerations for a surface mounted power device; Power Dissipation and RF Performance. In order to remove the dissipated power from this type chip they must be provided with adequate conductive cooling. This will prevent excessive chip temperatures leading to damage and early failure of the device. RF performance is also dependent on proper mounting. Since these devices are being mounted to a circuit board, inductance to ground is introduced by the vias to the ground plane. To reduce this effect and lower the thermal resistance between the component and ground plane, the following items are recommended:

1. Maximize the use of thermally conductive vias around and under the device.
2. Use of heavy copper cladding (2 oz.) on the circuit board as a heat spreader.

Solders

Aeroflex / Inmet recommends the use of the solders in the chart below when installing a surface mount chip. Also listed are recommended platings for the heatsink/baseplate that a device might be mounted to instead of a circuit board.

Mounting

The first step when mounting a chip device to the circuit board is to determine the proper size and location of the solder pads. Aeroflex / Inmet recommends providing pads that are 0.010" to 0.020" over the device's termination size and are centered on the axis of the chip. This allows for self-centering of the chip and a proper solder fillet formation. Skewing and "tombstoning" can occur if this is not followed. See Figure 2

Figure 1: High Power Flange Device Mounting

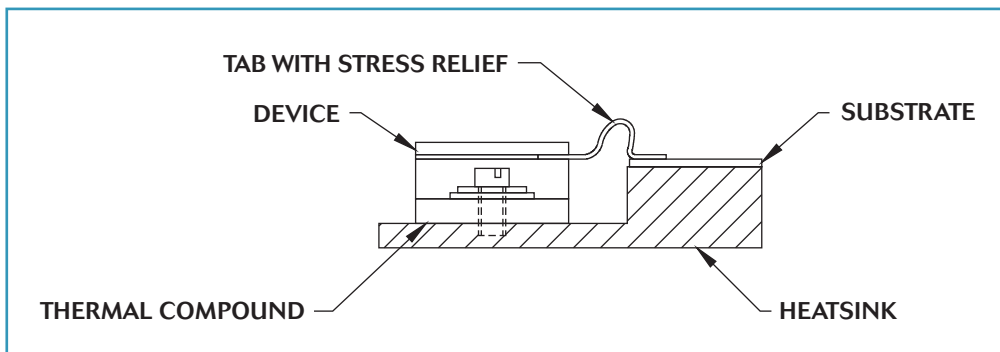

Preparation

1. Before any solder attachment, parts and circuit boards must be free of any oils or dirt. Isopropyl alcohol can be used for this task.
2. Apply a small amount of RMA flux (MIL-F-14256) to the areas to be soldered.
3. SN63 solder is generally recommended for use. This may be a preform, solder paste or wire. If preforms are used, select a size that is 0.005" to 0.010" larger than the size of the pad.
4. When soldering is complete the circuit board must be cleaned to remove any flux residue. This can be done in an ultrasonic cleaner or vapor degreaser. Flux manufacturers have recommended solvents or cleaning solutions for their products.

Pretinning

Pretinning can be done with either a solder pot or by depositing and reflowing solder on the device. (Aeroflex-Inmet can supply pretinned devices, SN63 or SN96).

Tabs

When attaching tabs to a device we recommend using SN96 (221° C) to attach the tab to the chip. Then, solder the tab to the circuit board using SN63 (183° C).

Wire Bonding

Attach the device to the circuit board using solder as described above. Clean and remove any flux residues. Ultrasonically bond wire or ribbon to gold termination pads using a wedge or ball bonder. NOTE: Gold plated chips are required for this method.

Tuning

Maximum VSWR, as specified on the data sheet, can be achieved without additional tuning. Lower VSWR can be achieved with stub or lumped element tuning. However, this can result in a narrower useable bandwidth.

Solder Type	Liquidous Temp. (degrees C.)	Recommended Platings for Heatsink/Baseplates
SN63	183 eutectic	Nickel, Silver
SN96	221 eutectic	Nickel, Silver
80Au/20Sn	280 eutectic	Gold over Nickel

Figure 2: Proper Mounting Techniques

