

MEST²GFC-10-25

PIN DIODE SWITCH ELEMENT

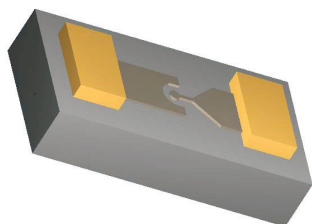

(MESTEG)



Description

A broadband medium power series switch element in chip form (26X12 mils). This is an Electrical Series device with a direct Thermal path to Ground (EST²G). It can be used in place of Beam Lead devices for medium power (up to 10 Watts) series switching. It is also suited for other applications from 100 MHz up to 40 GHz

Features

- Supports up to 10 watts power
- Low insertion loss typical 0.4 dB up to 40 GHz
- High Isolation typical 12 dB typical at 10 GHz

Maximum Ratings

RATING	LIMITS	UNITS
V_R	100	V
I_{FDC}	100	mA
θ_{JC}	60	°C/W
T_J	+175	°C
T_{STG}	-65 to +250	°C
T_{MTG}	+320 °C per 5 sec maximum	

Electrical Characteristics, $T_c = +25\text{ °C}$

SYMBOL	TEST CONDITIONS			MINIMUM	TYPICAL	MAXIMUM	UNITS
V_{BR}	$I_R = 10\ \mu\text{A}$			125	–	–	V
τ	$I_F = 10\ \text{mA}$	$I_R = 6\ \text{mA}$	10% / 90%	–	85	–	ns
W	I-Layer			–	8	–	μm
R_S	$I_F = 100\ \text{mA}$		500 MHz		2.0	–	ohms
I_L	$I_F = 50\ \text{mA}$		F = 10.0 GHz	–	0.3	0.4	dB
			F < 40.0 GHz	–	-0.4	–	dB
IRL	$I_F = 50\ \text{mA}$		F = 10.0 GHz	25	28	–	dB
			F < 40.0 GHz	–	15	–	dB
I_{So}	$V_R = -10\ \text{Volts}$		F = 10.0 GHz	10	12	–	dB
			F < 6.0 GHz	15	18	–	dB



Typical RF Performance at TA = 25 °C, Zo = 50 Ω, Small Signal

Insertion Loss

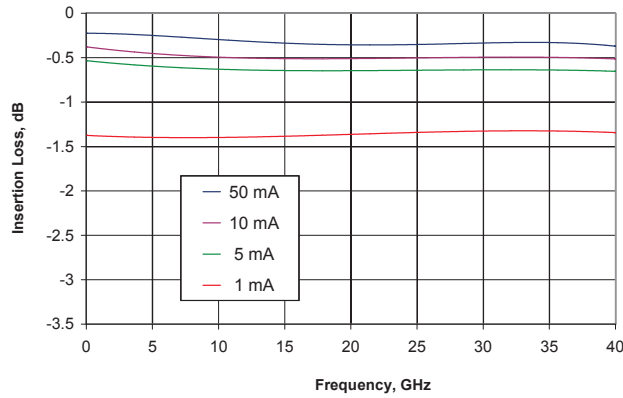

Isolation

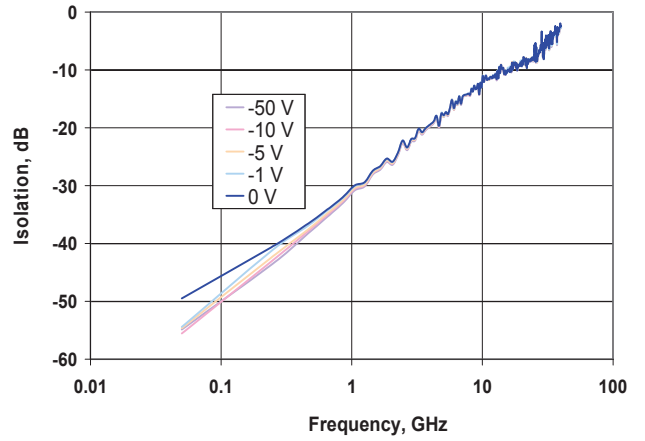

Input Return Loss

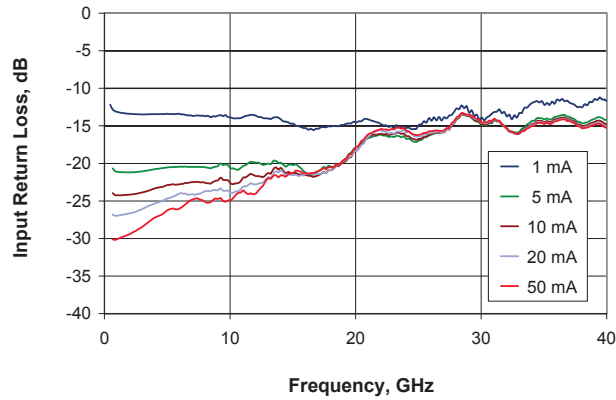

Capacitance

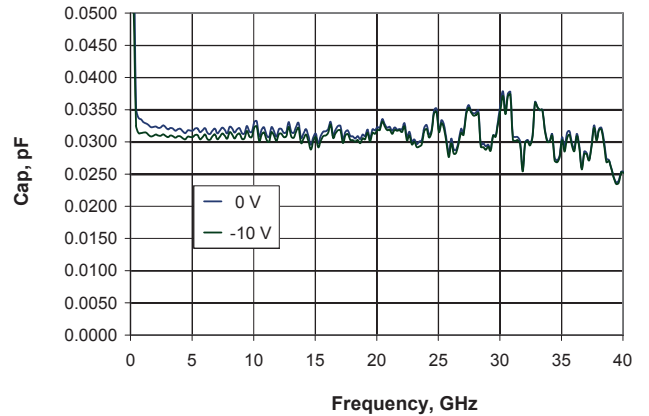

Package Outline

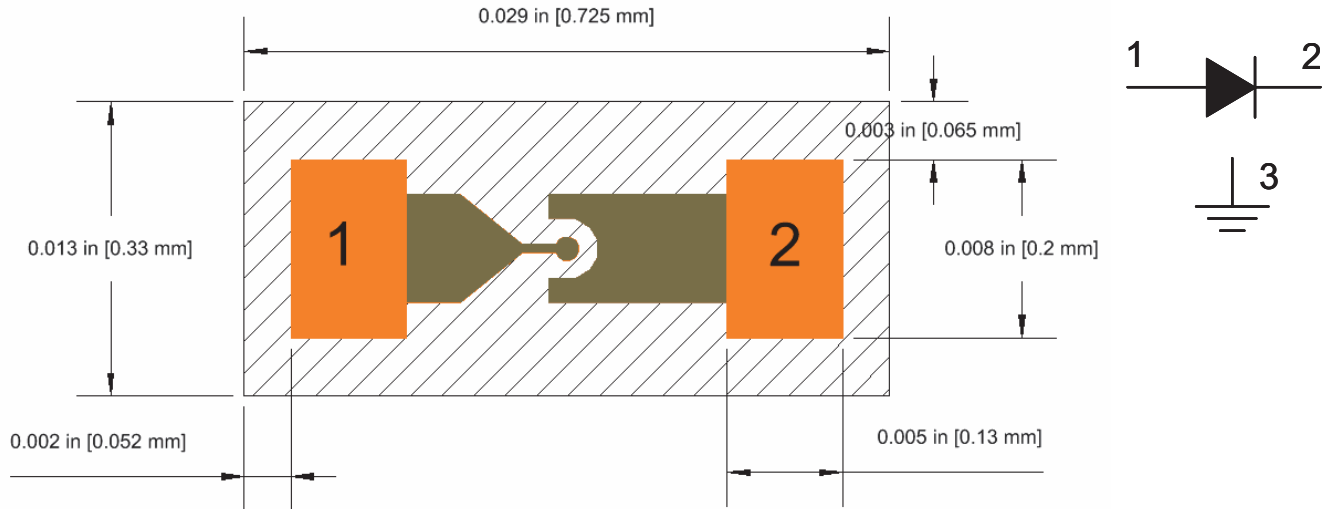

DIMENSIONS: INCHES [mm]
 CHIP THICKNESS: 5.5 MILS
 CHIP BACKSIDE: PLATED GOLD AND THERMAL GROUND
 BOND PADS: GOLD

Junction Temperature vs Input Power Mounted on Heat Sink 25°C Ambient, 1.3 GHz

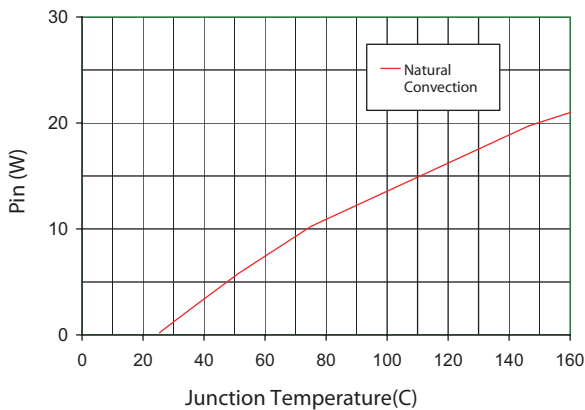

Resistance vs Current 500 MHz

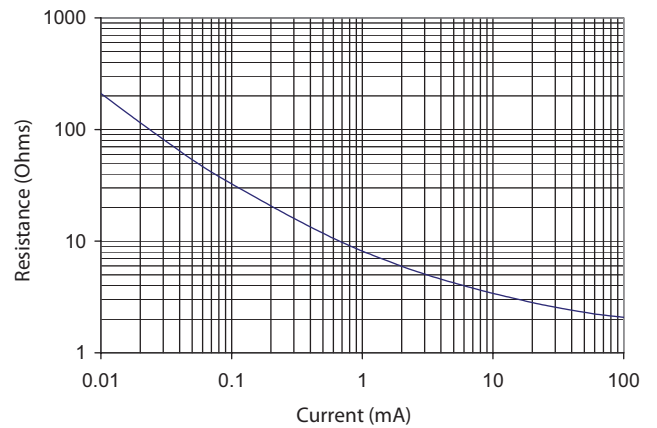

Aeroflex / Metelics Inc.

Aeroflex Microelectronic Solutions
975 Stewart Drive
Sunnyvale, CA 94085
TEL: 408-737-8181

54 Grenier Field Road
Londonderry, NH 03053
TEL: 603-641-3800

Sales

888-641-SEMI (7364)
metelics-sales@aeroflex.com

www.aeroflex.com/Microwave www.aeroflex.com/Metelics

Aeroflex / Metelics, Inc. reserves the right to make changes to any products and services herein at any time without notice. Consult Aeroflex or an authorized sales representative to verify that the information in this data sheet is current before using this product. Aeroflex does not assume any responsibility or liability arising out of the application or use of any product or service described herein, except as expressly agreed to in writing by Aeroflex; nor does the purchase, lease, or use of a product or service from Aeroflex convey a license under any patent rights, copyrights, trademark rights, or any other of the intellectual rights of Aeroflex or of third parties.

Copyright 2011 Aeroflex / Metelics. All rights reserved.

ISO 9001:2008 certified companies



Our passion for performance is defined by three attributes represented by these three icons: solution-minded, performance-driven and customer-focused.