

## A Battery Electronics Unit (BEU) for Balancing Lithium-Ion Batteries

**George Altemose**  
Aeroflex Plainview  
Plainview, New York 11803

Copyright © 2008 SAE International

### ABSTRACT

Lithium-ion batteries have become prominent in many applications, because of their high energy-to-weight ratio. Unlike other types of cells, lithium-ion cells do not exhibit natural cell-to-cell balancing mechanisms. Over time, lithium-ion batteries may become unbalanced, leading to one or more cells becoming overcharged, causing cell damage.

Cell balancing is required to achieve the maximum mission life for a lithium-ion battery, by reducing the possibility of overcharging or deep discharging. A BEU has been developed that uses a high-efficiency autonomous balancing circuit to maintain uniform charge on the series cells in a 24-cell battery. The balancing circuits operate continuously in all modes of operation, including charge, discharge and standby. The cell balancing currents are proportional to the voltage difference between the cells, gradually diminishing to zero as the cells achieve balance.

Each cell balancing circuit is a transformer-coupled forward converter with resonant reset, using planar transformers. A Phase Lock Loop (PLL) circuit provides zero-loss switching over the full range of variation due to changes in temperature and component aging.

In addition to cell balancing, the BEU also provides individual cell voltage monitoring, 1553 telemetry, reconditioning load control and cell bypass relay drivers.

Test data is presented that shows cell balancing and cell voltage monitoring accuracy of better than 10 millivolts, over a temperature range of -35 °C to +75°C.

### INTRODUCTION

Cell balancing circuits have been used for many years on virtually all battery technologies, including lead-acid, NiH<sub>2</sub>, NiMH and lithium-ion. Balancing is particularly desirable for lithium-ion batteries, because lithium-ion cells are susceptible to non-recoverable damage if they are either overcharged (typically to a voltage

greater than 4.3 volts) or excessively discharged (typically to a voltage less than 3.2 volts).

Traditional cell balancing circuits have used either of two technologies: dissipative (also known as charge-shunting) or active. In dissipative balancing circuits, shunt resistors are selectively connected across cells with higher voltages, thereby reducing the voltage of the shunted cell. The power in the resistor is dissipated as heat, and is not recoverable. This method is commonly used for commercial applications, such as power tools. Active balancing circuits, on the other hand, cause current to flow from cells with higher voltages to cells with lower voltages. By this method, charge is essentially conserved, with relatively small losses in the balancing circuit, and high efficiencies can be achieved.

Aeroflex has developed a Battery Electronics Unit (BEU) with active balancing, utilizing bidirectional DC-AC converters. The DC side of each converter is connected to one cell of the battery, and the AC sides of the converters are connected to a common node known as the Share Bus. If all cells are at precisely the same voltage, i.e. if the battery is perfectly balanced, no current flows through the converters, and no balancing currents flow in or out of the cells. However, if the battery becomes unbalanced, some cell voltages are greater than the average, and some are below the average. In this case, current flows from each high cell through its DC-AC converter into the Share Bus, and from the Share Bus to the low cells, through the converters of the low cells, in the reverse direction. Each converter is connected to the Share Bus through a resistor, typically 1 ohm. This resistor sets the Transfer Ratio, which is the ratio of the voltage imbalance (with respect to the average voltage) to the balancing current. For example, if the average cell voltage is 4.000 volts, but cell #6 is at 3.900 volts, the voltage imbalance for cell #6 is 0.100 volts and the balance current is 100 mA. In a 24-cell battery, the current from each nominal (average voltage) cell is:

$$100 \text{ mA}/23 = 4.348 \text{ mA}$$

Each nominal cell discharges 4.348 mA into the Share Bus to form the 100 mA charging current for cell #6. As a result, the voltages of the nominal cells decrease and the voltage of cell #6 increases, and all of the cell voltages asymptotically approach the average.

The Share Bus topology is illustrated in Figure 1, for both parallel and series arrangements of cells. In the parallel arrangement, the low sides of the cells are connected to a common ground and the high sides are connected to the Share Bus through individual 1 ohm resistors. The transfer function for each cell is

$$I_{CELL} = (V_{CELL} - V_{AVG}) / 1 \Omega$$

(Note that the parallel arrangement does not require a BEU, but is shown to illustrate the concept of call balancing through a Share Bus.)

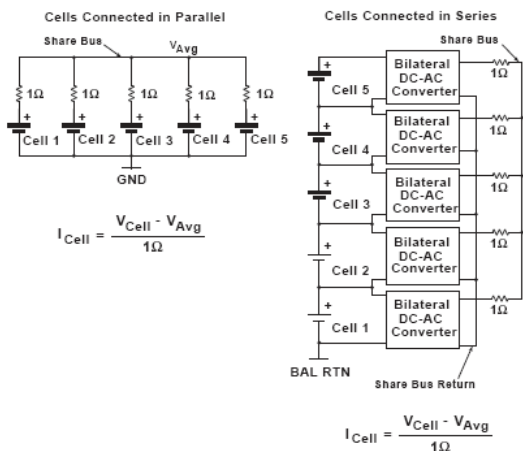

Figure 1 - Cell Balancing by Share Bus

In the series arrangement, the balancing problem is more complex because the series cells do not have a common ground. For this reason the BEU utilizes a set of bilateral DC-AC Converters. Each converter produces an AC voltage at its secondary side that is precisely equal to the DC voltage at its primary side. Each converter contains an isolation transformer. The low sides of the transformer secondaries are connected to a common node, which is the Share Bus Return. The high sides are connected through 1 ohm resistors to the Share Bus. The Share Bus voltage is equal to  $V_{AVG}$ , which is the average voltage of the cells. The transfer function for each individual cell is therefore

$$I_{CELL} = (V_{CELL} - V_{AVG}) / 1 \Omega$$

Thus, we can see that the Bilateral DC-AC Converters are basically acting as level translators, by preserving the differential cell voltages while removing the common mode component caused by the series connection of the cells.

### BALANCING AND MONITORING CIRCUITS

The basic cell balancing and monitoring circuit is shown in Figure 2, configured for a 5-cell battery. The circuit can be extended to accommodate a battery of virtually any size, and BEU's have been built and tested for batteries containing up to 24 cells. Figure 3 is a timing diagram, showing some of the key waveforms in the balancing and monitoring circuits. Figure 4 is a functional block diagram of a single BEU channel. Figure 4 also shows the mechanical partitioning of a 24-cell BEU, with 24 balancing circuits on the Cell Balance Board, and the ASIC controller, power supply, A/D converter and other circuits located on the Control Board.

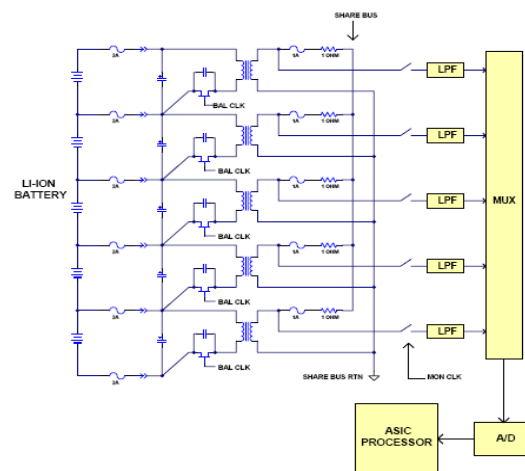

Figure 2 - Cell Balancing Circuit

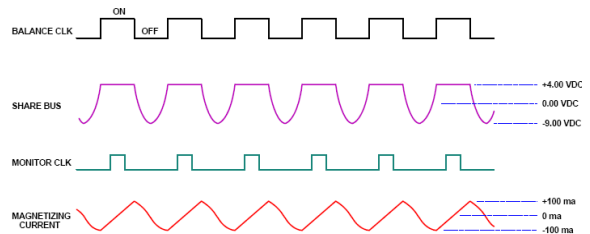
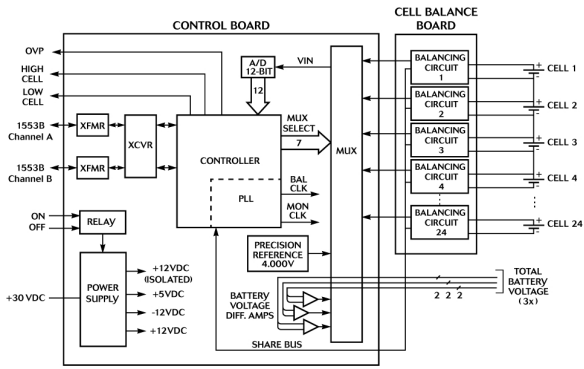

Figure 3 - Cell Balancing Timing Diagram



**Figure 4 - BEU Functional Block Diagram (Single Channel)**

The Balance Clock is the output of the Phase Lock Loop (PLL) and drives the N-channel FET's in the balancing circuits. The balance circuits have a natural resonant frequency, determined by the parallel combination of the primary inductances of the transformers and the resonating capacitors in parallel with the FET's. The duty cycle of the Balance Clock is exactly 50%, and the PLL sets the frequency to match the natural resonant frequency of the balancing circuits. The transformers are planar, with turns ratios of exactly 1:1. Therefore, during the ON half of the Balance Clock waveform, the voltage across the primary of the transformer in each converter is equal to the voltage of the cell to which it is connected, and the secondary voltage is also equal to this cell voltage. During this half-cycle, the transformer excitation current increases linearly. The slope of the current is equal to  $E/L$ , where  $E$  is the cell voltage and  $L$  is the primary inductance. During the OFF half-cycle, the FET current goes to zero, and the excitation current switches from the FET to the resonating capacitor. The stored energy in the inductance transfers from the inductance to the capacitance, and back to the inductance, producing a half-cycle of a sine wave. Because of the PLL, the FET turns on again at the start of the next cycle at precisely the time at which the capacitor voltage is zero, thereby providing nearly lossless switching and very high efficiency.

If all cell voltages are equal, the secondary voltages are equal, and no balancing currents flow through the 1 ohm resistors. In this condition, the cells are perfectly balanced. However, if any of the cell voltages differ from the average, the battery is in a state of imbalance, and currents flow through the corresponding 1 ohm resistors, in the direction from high secondary voltages to low secondary voltages, or from high cells to low cells.

The characteristic curve showing the transfer function for each balancing circuit is shown in

Figure 5. The Transfer Ratio,  $\Delta V / \Delta I$ , is the reciprocal of the slope of the line, and is quite constant for currents from zero to 1 ampere. The offset current,  $I_0$ , is a small current (typically 10 mA) that is present when the cells are in balance.  $I_0$  represents the circuit losses, primarily transformer core loss and dynamic switching loss that are always present, even though the cells are perfectly balanced.  $I_0$  is not part of the balancing current because it is identical for all cells, and therefore has no effect on cell balancing. However,  $I_0$  does constitute a discharge current for the battery. For relatively large batteries, e.g. with capacities on the order of 100 Ampere-hours or more, an  $I_0$  of 10 mA may have only a negligible effect on battery discharge. If necessary, the effect of  $I_0$  can be mitigated by invoking an algorithm in the control circuit that causes balancing to be performed at a controlled duty cycle, thereby reducing the effective discharge current. This algorithm first measures all of the cell voltages and determines whether or not all cells are balanced within a preset limit, e.g. 25 mV. If all cells are determined to be balanced, balancing is turned off for a fixed period, e.g. 5 seconds. At the end of this period, balancing is turned on again for 50 msec, which is 1% of the period, and the cells are again checked for balancing. As long as the cells remain balanced, the BEU continues to check them, with the balancing circuit enabled at a duty cycle of 1%. This reduces the effective  $I_0$  discharge current from 10 mA to 0.1 mA. If one or more cells become unbalanced, the balancing duty cycle reverts to 100% until full balance is achieved.

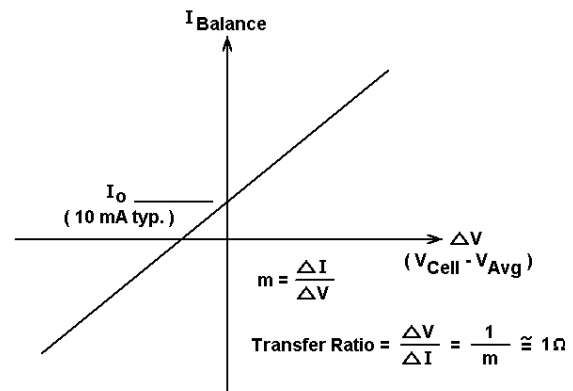

**Figure 5 - Cell Balancing Characteristic Curve**

Thus it has been shown that the balancing function is performed continuously and autonomously, over a wide range of cell voltages (the BEU operates with cell voltages from 2.0 volts to 4.5 volts), without the need to measure or process the cell voltages, and without the need for comparators, reference voltages or decision circuits.

In addition to cell balancing, the BEU also performs the function of cell voltage monitoring, wherein the voltage of each cell is measured, digitized (by a 12-bit A/D providing resolution of 1.25 mV), and sent by telemetry over a 1553B serial data bus to other terminals. As shown in Figure 2, each cell voltage is monitored at the secondary side of the balancing transformer. A sample-and-hold (S/H) circuit samples the secondary voltage during the ON time of the Balance Clock. The S/H ON time is controlled by the Monitor Clock. Both the Balance Clock and the Monitor Clock are generated by the PLL, which is part of the ASIC processor. From the S/H, the cell voltage passes through a low-pass filter (LPF) to the MUX, A/D and processor. As shown in Figure 4, the MUX inputs include 24 cell voltages, three differential amplifiers providing the total battery voltage and a precision 4.000 volt reference voltage. An additional input is the analog voltage ground.

The three total battery voltage differential amplifiers contain precision resistor divider networks to attenuate the total battery voltage by a factor of precisely 24, thereby normalizing the total battery voltage from 96 volts to 4 volts. During each conversion cycle, each of the 29 inputs (24 cell voltages, 3 total battery voltages, 4.000 volt reference and analog ground) is digitized by the A/D and saved in memory. A slope and offset correction is then calculated for each of the 27 cell and battery measurements, using the 4.000 volt reference as the standard. This process compensates for any small gain and offset errors that may exist in the MUX and A/D.

#### **ASIC CONTROLLER**

To meet the size, weight, reliability, radiation hardness and power consumption requirements of the digital electronics for the BEU, a proprietary ASIC was developed. The device was fabricated in the Aeroflex Colorado Springs 0.6  $\mu$ m Commercial Rad Hard CMOS Gate Array process.

Highlighted features of the ASIC include:

- 145K equivalent gates, including a 2048x18 bit RAM.
- Single 5V power supply; ~300 mW dissipation.
- RHA Class R (100K Rad).

- 256-pin Ceramic Quad Flat Pack (CQFP).
- Single 48-MHz clock input.
- JTAG (IEEE 1149.1 compliant) boundary scan.

Highlighted functionality of the ASIC:

- Control, calibration of external A/D and storage in RAM of various analog telemetry measurements.
- Control and monitoring of cell bypass device drivers.
- Digital PLL for generation of clocks for cell balancing.
- Control and monitoring of reconditioning load switches.
- Sync pulse to 5V switching power supply.
- Watchdog timer functionality and support.
- Optional serial cross-strapping to a peer ASIC.
- RS-422 serial communication port for RAM access in development and test.

The ASIC contains a sequencer state machine which is capable of executing a set of micro-coded instructions to perform a variety of functions. The sequencer is able to fetch firmware instructions from the internal ASIC RAM or from an external 4Kx8 PROM.

#### **BYPASS RELAY DRIVER**

As an optional feature, a bypass relay may be provided for each cell in the battery. In normal conditions, the relays are deactivated and all 24 cells are connected in a series string, thereby providing a nominal 96 volts for a 24-cell battery. If any cell is found to have failed, its bypass relay can be activated. This removes the cell from the series string and replaces it with a short circuit. In effect, the 24-cell battery becomes a 23-cell battery, with a voltage of 92 volts. The relay used in this application has been designed specifically for this purpose. It has a "make-before-break" contact arrangement, and it can be activated only one time; once activated, it is permanently latched, and cannot be deactivated. The activation pulse is 1 ampere for 100 milliseconds, and it opens a fusible link that cannot be reversed.

The bypass relays are physically installed in the battery housing, and are activated from the BEU through a cable, which may be several meters in length. To energize a bypass relay, the BEU must receive three independent 1553 commands, designated "Master Enable," "Arm," and "Bypass." These driver circuits are located on the Relay Driver Board. If a battery system includes bypass relays, the BEU includes a Relay Driver Board. (If bypass relays are not required, the Relay Driver Board is omitted.) A Relay Driver Board may be used in either a dual redundant BEU (with two Control Boards) or a single channel BEU (with one Control Board).

### BEU CONFIGURATIONS

The basic building blocks of the BEU are three printed circuit cards:

- Control Board (contains ASIC, power supply, 1553 interface)
- Cell Balance Board (contains 24 cell balancing circuits)
- Relay Driver Board (contains bypass relay drivers and recon load control)

These cards are identical in size, 5" in height and 11" in width. They can be interconnected to form various system configurations, with the simplest configuration being one Control Board and one Balancing Board to form a single channel 24-cell unit, providing cell balancing, cell monitoring and 1553 telemetry. If bypass relays are used, a Relay Driver Board can be added. If dual redundant balancing is desired, a second Control Board and Cell Balance Board can be included.

### TIME TO ACHIEVE BALANCE

The time required for the battery to achieve balance depends on four factors:

- 1) The ampere-hour rating of the battery (measured in ampere-hours/volt).
- 2) The Transfer Ratio (RT) of the BEU (measured in ohms).
- 3) The initial imbalance voltage.
- 4) The definition of "balance voltage" (typically 25 mV).

$$T_{bal} = (\tau) \ln [V_{start}/V_{bal}]$$

$$\tau = (\text{Transfer Ratio})(\text{A-hr capacity of battery})$$

where

$T_{bal}$  is the time to achieve the defined balance voltage.

$\tau$  is the balance time constant.

$V_{start}$  is the initial imbalance voltage.

$V_{bal}$  is the defined balance voltage.

Transfer Ratio is the ratio of  $\Delta V / \Delta I$  of the BEU

### TEST RESULTS

Tests of the BEU at temperatures of -35 °C, +25 °C and +75 °C were performed. Capacitors were used instead of lithium-ion cells, in order to achieve shorter test times. Measurements were made of the "cell voltages" (actually the capacitor voltages), with 96.000 volts applied across the entire battery. The monitor voltages were measured by the BEU and sent via the 1553 data bus to a data logger. Ideally, each cell voltage should be exactly 4.000 volts, and each monitor voltage should be exactly equal to the cell voltage.

The static test results are shown in Figures 6, 7 and 8. All of the balanced cell voltages are within 6 mV of the average cell voltage, which is 4.000 volts.

A typical dynamic response diagram is shown in Figure 9. This test was performed on a different BEU, with a higher Transfer Ratio, and with a battery containing 13 cells, rated at 300 mA-hr. The cells were intentionally unbalanced prior to beginning the test, and are seen to be converging toward the average cell voltage, which is approximately 3.862 volts. When the test was stopped, all 13 cell voltages were within less than 10 mV of each other, and were continuing to converge.

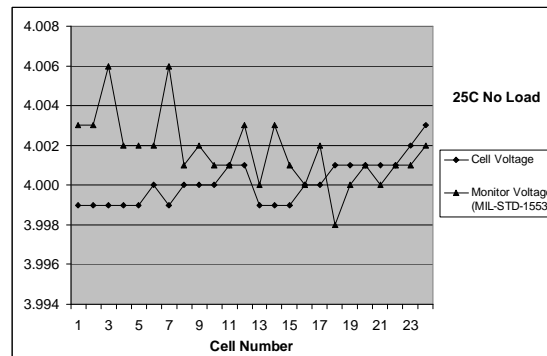

Figure 6

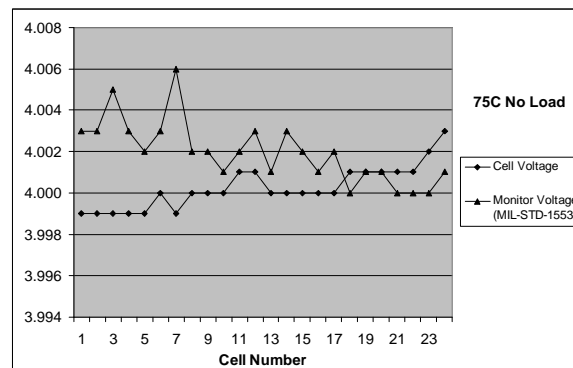

Figure 7

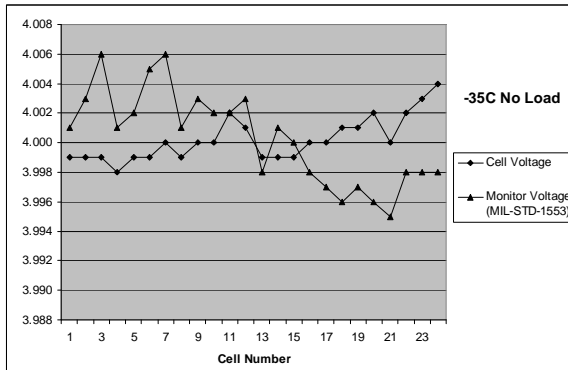

Figure 8

**CONCLUSION**

A BEU has been developed using an autonomous active non-dissipative technique for balancing lithium-ion battery cells with an accuracy of better than 10 mV. The BEU also provides cell voltage monitoring with 10 mV accuracy and telemetry over a 1553 serial data bus. The BEU is fully developed, and has passed qualification tests including EMI, shock and vibration, pyroshock, temperature cycling and thermal vacuum. The EMI test included Conducted Emitted (CE), Conducted

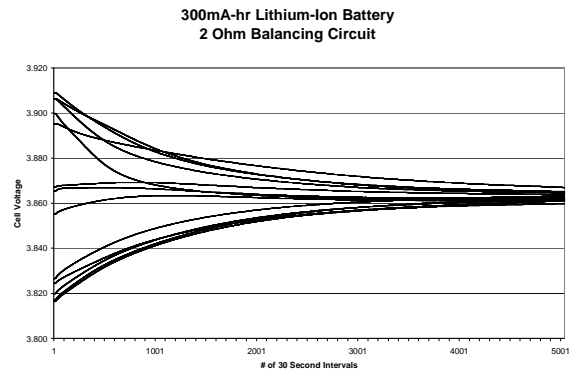

Figure 9 - Balancing of 13 Cell Battery

Susceptibility (CS), Radiated Emitted (RE) and Radiated Susceptibility (RS).

**ACKNOWLEDGEMENT**

The conceptual design of the BEU was performed by Boeing Space Systems, and is described in patent US 6,873,134 B2. Aeroflex designed and developed the original BEU in accordance with Boeing Space Systems specifications. Aeroflex currently has three patents pending relating to improvements to the BEU.