

**NOTE:** This product has been replaced with UT28F256LVQLE or SMD 5962-01517 device types 04 and 05.

# UT28F256LV Radiation-Hardened 32K x 8 PROM



December, 2002

## FEATURES

- ❑ Programmable, read-only, asynchronous, radiation-hardened, 32K x 8 memory
  - Supported by industry standard programmer
- ❑ 65ns maximum address access time (-55 °C to +125 °C)
- ❑ Three-state data bus
- ❑ Low operating and standby current
  - Operating: 50.0mA maximum @15.4MHz
    - Derating: 1.5mA/MHz
  - Standby: 1.0mA maximum (post-rad)
- ❑ Radiation-hardened process and design; total dose irradiation testing to MIL-STD-883, Method 1019
  - Total dose: 1E6 rad(Si)
  - $LET_{TH}(0.25) \sim 100 \text{ MeV-cm}^2/\text{mg}$
  - SEL Immune  $\geq 128 \text{ MeV-cm}^2/\text{mg}$
  - Saturated Cross Section  $\text{cm}^2$  per bit,  $1.0\text{E-}11$
  - $1.2\text{E-}8$  errors/device-day, Adams 90% geosynchronous heavy ion
  - Memory cell LET threshold:  $>128 \text{ MeV-cm}^2/\text{mg}$

- ❑ QML Q & V compliant part
  - AC and DC testing at factory
- ❑ Packaging options:
  - 28-lead 50-mil center flatpack (0.490 x 0.74)
  - 28-lead 100-mil center DIP (0.600 x 1.4) - contact factory
- ❑  $V_{DD}$ : 3.0Vto 3.6V
- ❑ Standard Microcircuit Drawing 5962-01517

## PRODUCT DESCRIPTION

The UT28F256LV amorphous silicon anti-fuse PROM is a high performance, asynchronous, radiation-hardened, 32K x 8 programmable memory device. The UT28F256LV PROM features fully asynchronous operation requiring no external clocks or timing strobes. An advanced radiation-hardened twin-well CMOS process technology is used to implement the UT28F256LV. The combination of radiation-hardness, fast access time, and low power consumption make the UT28F256LV ideal for high speed systems designed for operation in radiation environments.

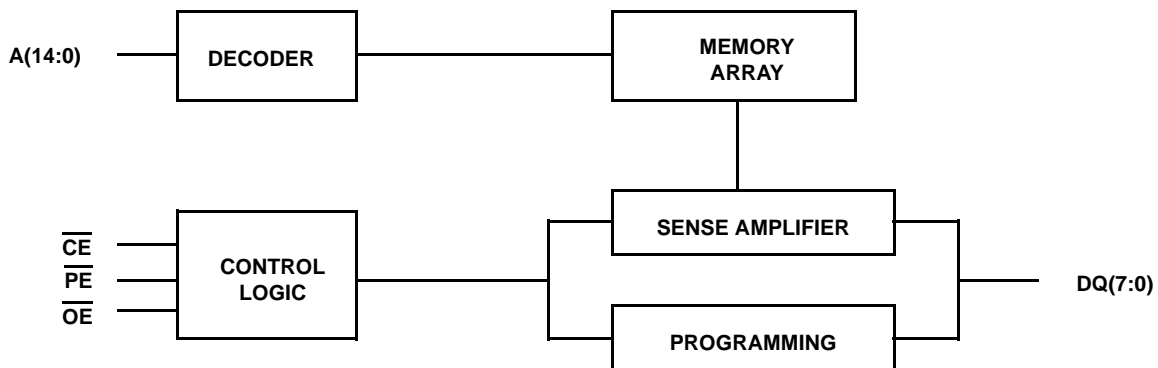
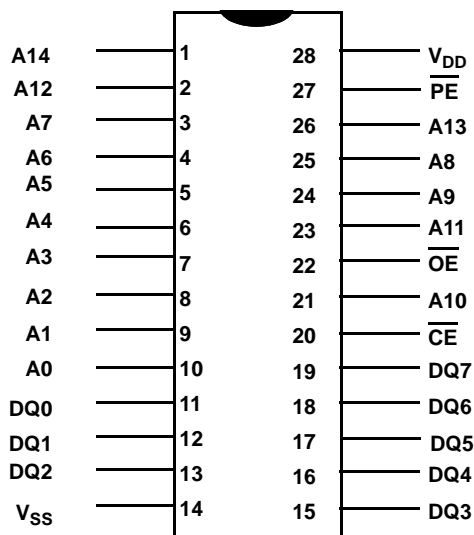

Figure 1. PROM Block Diagram

## DEVICE OPERATION

The UT28F256LV has three control inputs: Chip Enable ( $\overline{CE}$ ), Program Enable ( $\overline{PE}$ ), and Output Enable ( $\overline{OE}$ ); fifteen address inputs, A(14:0); and eight bidirectional data lines, DQ(7:0).  $\overline{CE}$  is the device enable input that controls chip selection, active, and standby modes. Asserting  $\overline{CE}$  causes  $I_{DD}$  to rise to its active value and decodes the fifteen address inputs to select one of 32,768 words in the memory.  $\overline{PE}$  controls program and read operations. During a read cycle,  $\overline{OE}$  must be asserted to enable the outputs.

## PIN CONFIGURATION



## PIN NAMES

A(14:0)	Address
$\overline{CE}$	Chip Enable
$\overline{OE}$	Output Enable
$\overline{PE}$	Program Enable
DQ(7:0)	Data Input/Data Output

**Table 1. Device Operation Truth Table <sup>1</sup>**

$\overline{OE}$	$\overline{PE}$	$\overline{CE}$	I/O MODE	MODE
X	1	1	Three-state	Standby
0	1	0	Data Out	Read
1	0	0	Data In	Program
1	1	0	Three-state	Read <sup>2</sup>

**Notes:**

1. "X" is defined as a "don't care" condition.
2. Device active; outputs disabled.

## ABSOLUTE MAXIMUM RATINGS <sup>1</sup>

(Referenced to  $V_{SS}$ )

SYMBOL	PARAMETER	LIMITS	UNITS
$V_{DD}$	DC supply voltage	-0.3 to 7.0	V
$V_{I/O}$	Voltage on any pin	-0.5 to ( $V_{DD} + 0.5$ )	V
$T_{STG}$	Storage temperature	-65 to +150	°C
$P_D$	Maximum power dissipation	1.5	W
$T_J$	Maximum junction temperature	+175	°C
$\Theta_{JC}$	Thermal resistance, junction-to-case <sup>2</sup>	3.3	°C/W
$I_I$	DC input current	$\pm 10$	mA

**Notes:**

1. Stresses outside the listed absolute maximum ratings may cause permanent damage to the device. This is a stress rating only, and functional operation of the device at these or any other conditions beyond limits indicated in the operational sections of this specification is not recommended. Exposure to absolute maximum rating conditions for extended periods may affect device reliability.
2. Test per MIL-STD-883, Method 1012, infinite heat sink.

## RECOMMENDED OPERATING CONDITIONS

SYMBOL	PARAMETER	LIMITS	UNITS
$V_{DD}$	Positive supply voltage	3.0 to 3.6	V
$T_C$	Case temperature range	-55 to +125	°C
$V_{IN}$	DC input voltage	0 to $V_{DD}$	V

## DC ELECTRICAL CHARACTERISTICS (Pre/Post-Radiation)\*

( $V_{DD} = 3.0V$  to  $3.6V$ ;  $-55^{\circ}C < T_C < +125^{\circ}C$ )

SYMBOL	PARAMETER	CONDITION	MINIMUM	MAXIMUM	UNIT
$V_{IH}$	High-level input voltage		$0.7V_{DD}$		V
$V_{IL}$	Low-level input voltage			$0.25V_{DD}$	V
$V_{OL1}$	Low-level output voltage	$I_{OL} = 100\mu A$ , $V_{DD} = 3.0V$		$V_{SS} + 0.05$	V
$V_{OL2}$	Low-level output voltage	$I_{OL} = 1.0mA$ , $V_{DD} = 3.0V$		$V_{SS} + 0.10$	V
$V_{OH1}$	High-level output voltage	$I_{OH} = -100\mu A$ , $V_{DD} = 3.0V$	$V_{DD} - 0.15$		V
$V_{OH2}$	High-level output voltage	$I_{OH} = -1.0mA$ , $V_{DD} = 3.0V$	$V_{DD} - 0.3$		V
$C_{IN}^1$	Input capacitance	$f = 1MHz$ , $V_{DD} = 3.3V$ $V_{IN} = 0V$		15	pF
$C_{IO}^{1,4}$	Bidirectional I/O capacitance	$f = 1MHz$ , $V_{DD} = 3.3V$ $V_{OUT} = 0V$		15	pF
$I_{IN}$	Input leakage current	$V_{IN} = 0V$ to $V_{DD}$	-3	3	$\mu A$
$I_{OZ}$	Three-state output leakage current	$V_O = 0V$ to $V_{DD}$ $V_{DD} = 3.6V$ $\overline{OE} = 3.6V$	-8	8	$\mu A$
$I_{OS}^{2,3}$	Short-circuit output current	$V_{DD} = 3.6V$ , $V_O = V_{DD}$ $V_{DD} = 3.6V$ , $V_O = 0V$	-90	90	mA mA
$I_{DD1}(OP)^5$	Supply current operating @ 15.4MHz (65ns product)	CMOS input levels ( $I_{OUT} = 0$ ), $V_{IL} = 0.2V$ $V_{DD}$ , $\overline{PE} = 3.6V$ , $V_{IH} = 3.0V$		50.0	mA
$I_{DD2}(SB)$ post-rad	Supply current standby	CMOS input levels $V_{IL} = V_{SS} + 0.25V$ $\overline{CE} = V_{DD} - 0.25V$ , $V_{IH} = V_{DD} - 0.25V$		1.0	mA

### Notes:

\* Post-radiation performance guaranteed at 25°C per MIL-STD-883 Method 1019 at 1E6 rad(Si).

1. Measured only for initial qualification, and after process or design changes that could affect input/output capacitance.
2. Supplied as a design limit but not guaranteed or tested.
3. Not more than one output may be shorted at a time for maximum duration of one second.
4. Functional test.
5. Derates at 1.5mA/MHz.

## READ CYCLE

A combination of  $\overline{PE}$  greater than  $V_{IH}(\min)$ , and  $\overline{CE}$  less than  $V_{IL}(\max)$  defines a read cycle. Read access time is measured from the latter of device enable, output enable, or valid address to valid data output.

An address access read is initiated by a change in address inputs while the chip is enabled with  $\overline{OE}$  asserted and  $\overline{PE}$  deasserted. Valid data appears on data output, DQ(7:0), after the specified  $t_{AVQV}$  is satisfied. Outputs remain active throughout the entire cycle. As long as device enable and output enable are active, the address inputs may change at a rate equal to the minimum read cycle time.

The chip enable-controlled access is initiated by  $\overline{CE}$  going active while  $\overline{OE}$  remains asserted,  $\overline{PE}$  remains deasserted, and the addresses remain stable for the entire cycle. After the specified  $t_{ELQV}$  is satisfied, the eight-bit word addressed by A(14:0) appears at the data outputs DQ(7:0).

Output enable-controlled access is initiated by  $\overline{OE}$  going active while  $\overline{CE}$  is asserted,  $\overline{PE}$  is deasserted, and the addresses are stable. Read access time is  $t_{GLQV}$  unless  $t_{AVQV}$  or  $t_{ELQV}$  have not been satisfied.

### AC CHARACTERISTICS READ CYCLE (Post-Radiation)\* ( $V_{DD} = 3.0V$ to $3.6V$ ; $-55^{\circ}C < T_C < +125^{\circ}C$ )

SYMBOL	PARAMETER	28F256LV-65		UNIT
		MIN	MAX	
$t_{AVAV}^1$	Read cycle time	65		ns
$t_{AVQV}$	Read access time		65	ns
$t_{AXQX}^2$	Output hold time	0		ns
$t_{GLQX}^2$	$\overline{OE}$ -controlled output enable time	0		ns
$t_{GLQV}$	$\overline{OE}$ -controlled access time		35	ns
$t_{GHQZ}$	$\overline{OE}$ -controlled output three-state time		35	ns
$t_{ELQX}^2$	$\overline{CE}$ -controlled output enable time	0		ns
$t_{ELQV}$	$\overline{CE}$ -controlled access time		65	ns
$t_{EHQZ}$	$\overline{CE}$ -controlled output three-state time		35	ns

#### Notes:

\* Post-radiation performance guaranteed at 25°C per MIL-STD-883 Method 1019 at 1E6 rads(Si).

1. Functional test.

2. Three-state is defined as a 400mV change from steady-state output voltage.

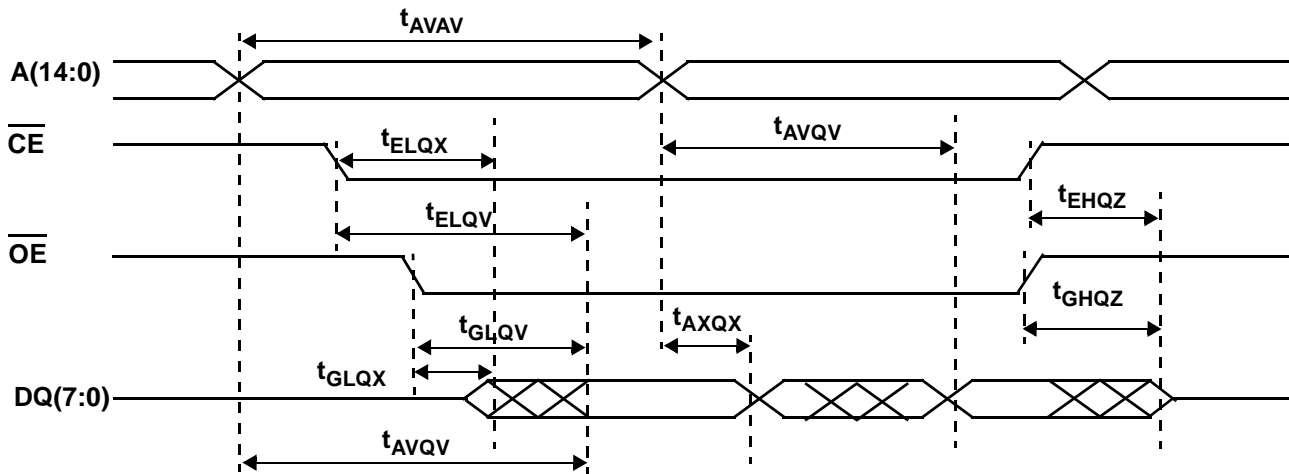

Figure 2. PROM Read Cycle

### RADIATION HARDNESS

The UT28F256LV PROM incorporates special design and layout features which allow operation in high-level radiation environments. UPMC has developed special low-temperature processing techniques designed to enhance the total-dose radiation hardness of both the gate oxide and the field oxide while

maintaining the circuit density and reliability. For transient radiation hardness and latchup immunity, UPMC builds all radiation-hardened products on epitaxial wafers using an advanced twin-tub CMOS process. In addition, UPMC pays special attention to power and ground distribution during the design phase, minimizing dose-rate upset caused by rail collapse.

### RADIATION HARDNESS DESIGN SPECIFICATIONS <sup>1</sup>

Total Dose	1E6	rad(Si)
Latchup LET Threshold	>128	MeV-cm <sup>2</sup> /mg
Memory Cell LET Threshold	>128	MeV-cm <sup>2</sup> /mg
Transient Upset LET Threshold	54	MeV-cm <sup>2</sup> /mg
Transient Upset Device Cross Section @ LET=128 MeV-cm <sup>2</sup> /mg	1E-6	cm <sup>2</sup>

**Note:**

1. The PROM will not latchup during radiation exposure under recommended operating conditions.

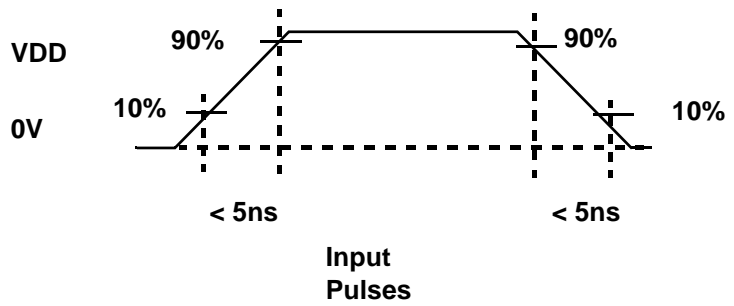
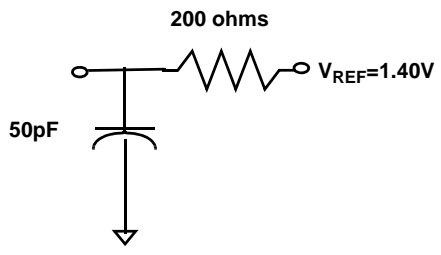

**Notes:**

1. 50pF including scope probe and test socket.
2. Measurement of data output occurs at the low to high or high to low transition mid-point .

**Figure 3. AC Test Loads and Input Waveforms**

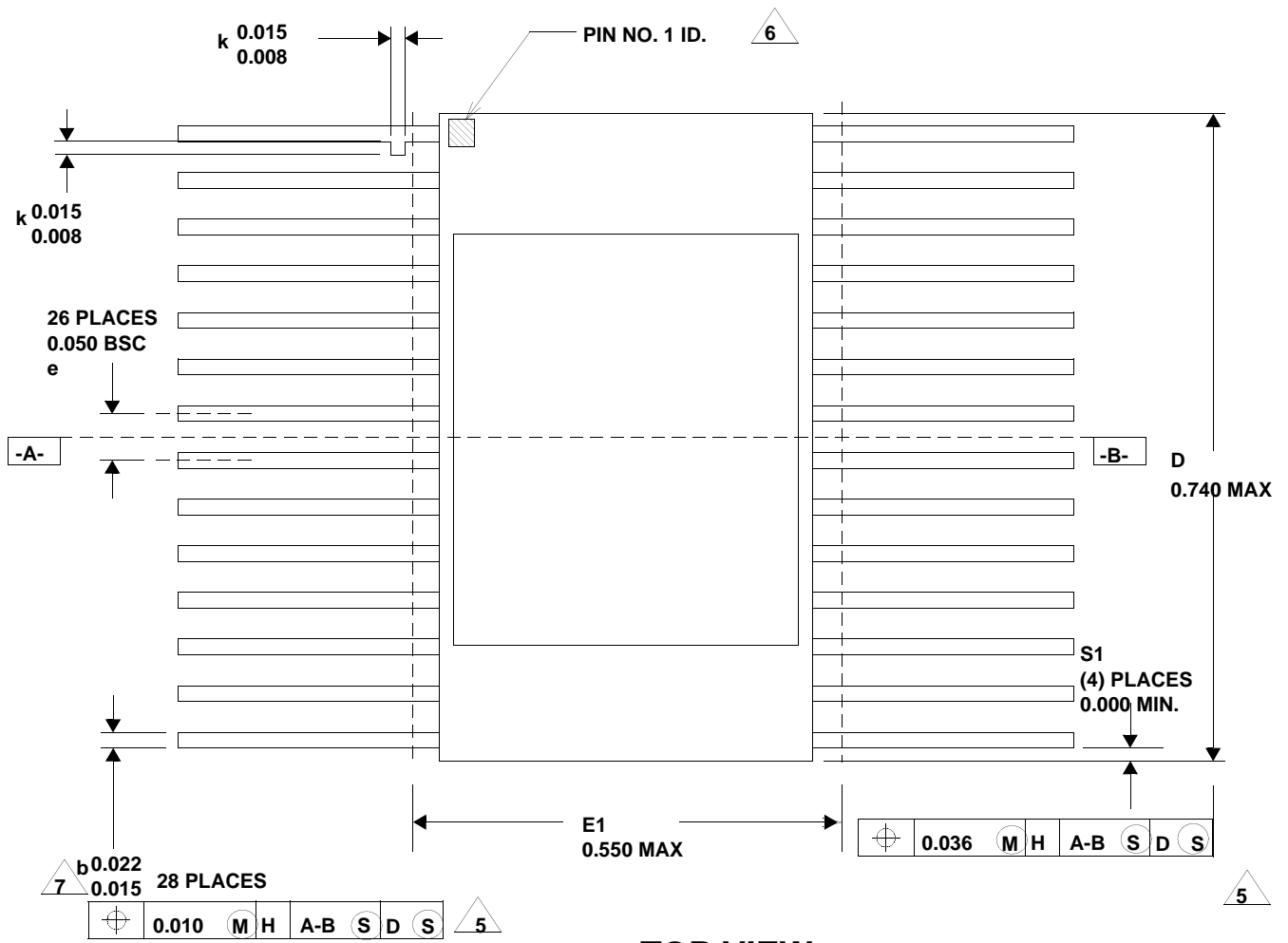

**TOP VIEW**



**END VIEW**

- Notes:**
1. All exposed metallized areas to be plated per MIL-PRF-38535.
  2. The lid is connected to  $V_{SS}$ .
  3. Lead finishes are in accordance with MIL-PRF-38535.
  4. Dimension letters refer to MIL-STD-1835.
  5. Lead position and coplanarity are not measured.
  6. ID mark symbol is vendor option.
  7. With solder, increase maximum by 0.003.
  8. Total weight is approximately 2.4 grams.

**Figure 5. 28-Lead 50-mil Center Flatpack (0.490 x 0.74)**

# ORDERING INFORMATION

## UT28F256LV PROM: SMD

5962 \* 01517 \* \* \* \*

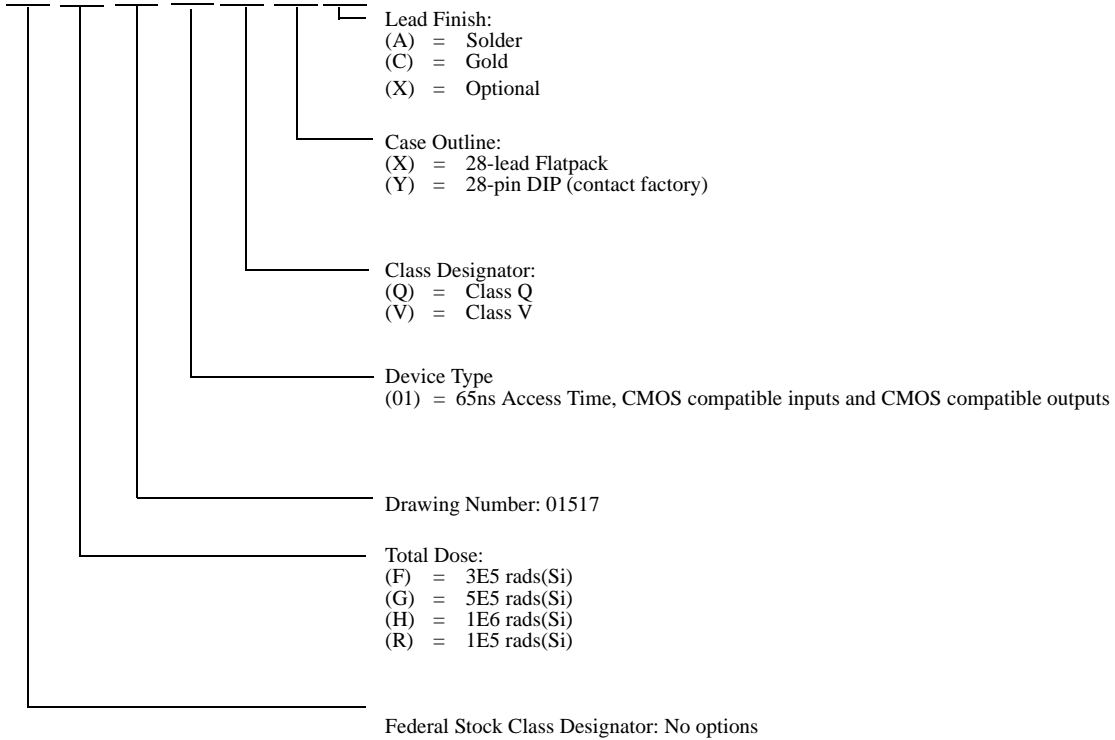

### Notes:

1. Lead finish (A, C, or X) must be specified.
2. If an "X" is specified when ordering, part marking will match the lead finish and will be either "A" (solder) or "C" (gold).
3. Total dose radiation must be specified when ordering. QML Q and QML V not available without radiation hardening.
4. Lead finish: Factory programming either solder or gold. Field programming gold only.

# UT28F256LV PROM

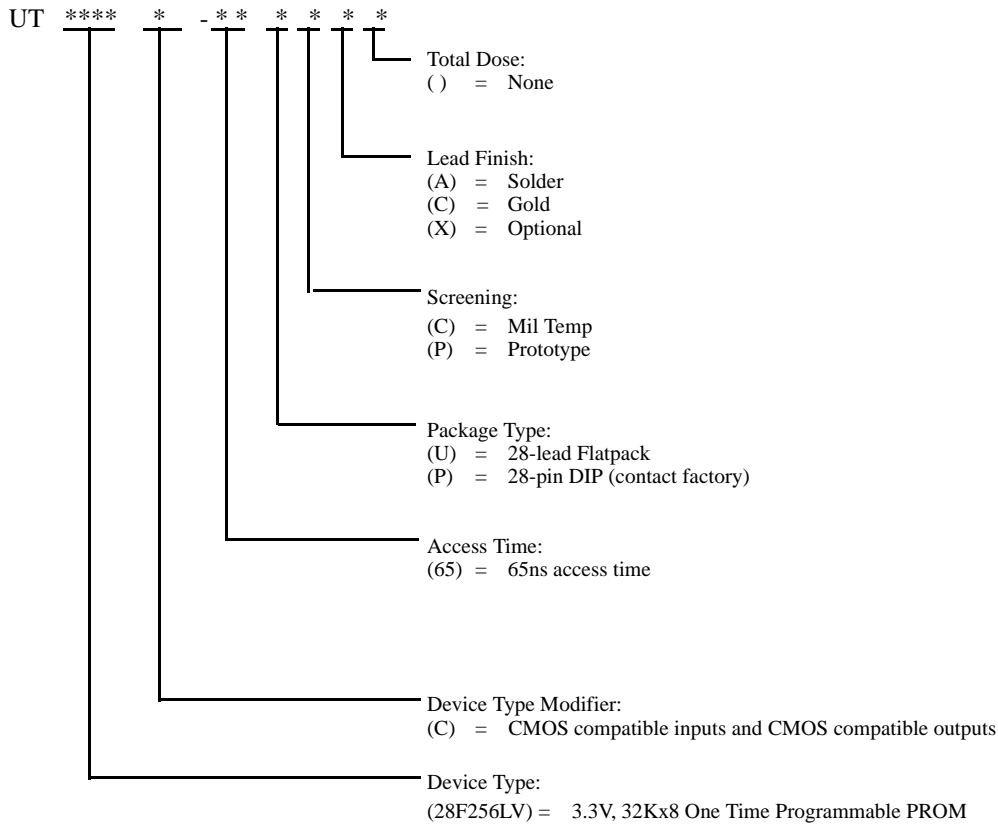

**Notes:**

1. Lead finish (A,C, or X) must be specified.
2. If an "X" is specified when ordering, then the part marking will match the lead finish and will be either "A" (solder) or "C" (gold).
3. Military Temperature Range flow per UTMC Manufacturing Flows Document. Radiation characteristics are neither tested nor guaranteed and may not be specified.
4. Prototype flow per UTMC Manufacturing Flows Document. Devices have prototype assembly and are tested at 25°C only. Radiation characteristics are neither tested nor guaranteed and may not be specified.
5. Lead finish: Factory programming either solder or gold. Field programming gold only.

## Notes