

UT54LVDS031LV/E Low Voltage Quad Driver

Data Sheet

October 26, 2011

www.aeroflex.com/lvds



FEATURES

- ❑ >400.0 Mbps (200 MHz) switching rates
- ❑ $\pm 340\text{mV}$ nominal differential signaling
- ❑ 3.3 V power supply
- ❑ TTL compatible inputs
- ❑ Cold sparing all pins
- ❑ Ultra low power CMOS technology
- ❑ 1.5ns maximum, propagation delay
- ❑ 310ps maximum, differential skew
- ❑ Operational environment; total dose irradiation testing to MIL-STD-883 Method 1019
 - Total-dose: 300 krad(Si) and 1Mrad(Si)
 - Latchup immune (LET > 100 MeV-cm²/mg)
- ❑ Packaging options:
 - 16-lead flatpack (dual in-line), weight 0.7 grams
- ❑ Standard Microcircuit Drawing 5962-98651
 - QML Q and V compliant part
- ❑ Compatible with ANSI/TIA/EIA-644 Standard

INTRODUCTION

The UT54LVDS031LV Quad Driver is a quad CMOS differential line driver designed for applications requiring ultra low power dissipation and high data rates. The device is designed to support data rates in excess of 400.0 Mbps (200 MHz) utilizing Low Voltage Differential Signaling (LVDS) technology.

The UT54LVDS031LV accepts low voltage TTL input levels and translates them to low voltage (340mV) differential output signals. In addition, the driver supports a three-state function that may be used to disable the output stage, disabling the load current, and thus dropping the device to an ultra low idle power state.

The UT54LVDS031LV and companion quad line receiver UT54LVDS032LV provide new alternatives to high power pseudo-ECL devices for high speed point-to-point interface applications.

All pins have Cold Spare buffers. These buffers will be high impedance when V_{DD} is tied to V_{SS} .

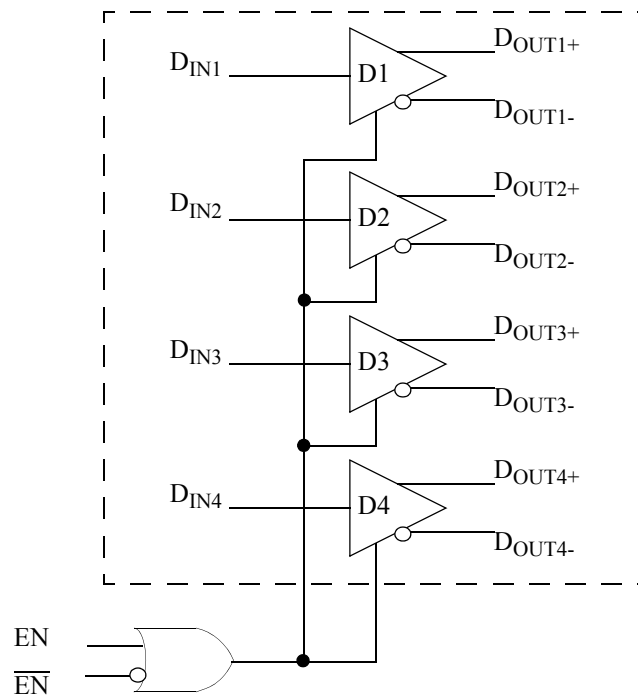

Figure 1. UT54LVDS031LV Quad Driver Block Diagram

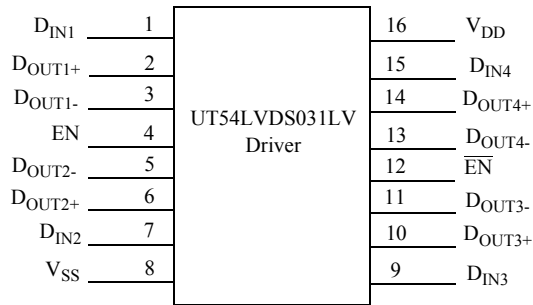

Figure 2. UT54LVDS031LV Pinout

TRUTH TABLE

Enables		Input	Output	
EN	EN-bar	D _{IN}	D _{OUT+}	D _{OUT-}
L	H	X	Z	Z
All other combinations of ENABLE inputs		L	L	H
		H	H	L

PIN DESCRIPTION

Pin No.	Name	Description
1, 7, 9, 15	D _{IN}	Driver input pin, TTL/CMOS compatible
2, 6, 10, 14	D _{OUT+}	Non-inverting driver output pin, LVDS levels
3, 5, 11, 13	D _{OUT-}	Inverting driver output pin, LVDS levels
4	EN	Active high enable pin, OR-ed with EN-bar
12	EN-bar	Active low enable pin, OR-ed with EN
16	V _{DD}	Power supply pin, +3.3V ± 0.3V
8	V _{SS}	Ground pin

APPLICATIONS INFORMATION

The UT54LVDS031LV driver’s intended use is primarily in an uncomplicated point-to-point configuration as is shown in Figure 3. This configuration provides a clean signaling environment for quick edge rates of the drivers. The receiver is connected to the driver through a balanced media such as a standard twisted pair cable, a parallel pair cable, or simply PCB traces. Typically, the characteristic impedance of the media is in the range of 100Ω. A termination resistor of 100Ω should be selected to match the media and is located as close to the receiver input pins as possible. The termination resistor converts the current sourced by the driver into voltages that are detected by the receiver. Other configurations are possible such as a multi-receiver configuration, but the effects of a mid-stream connector(s), cable stub(s), and other impedance discontinuities, as well as ground shifting, noise margin limits, and total termination loading must be taken into account.

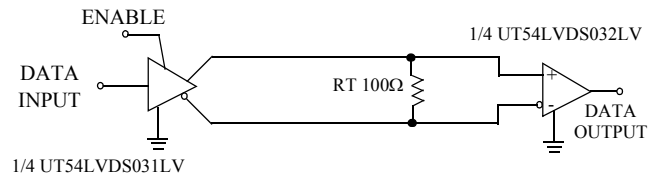
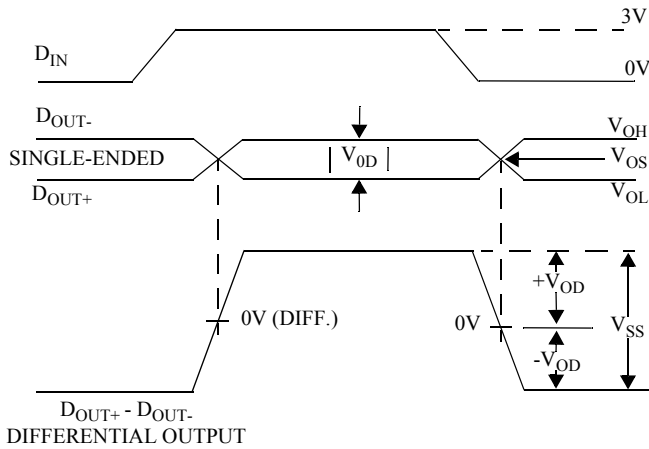

Figure 3. Point-to-Point Application

The UT54LVDS031LV differential line driver is a balanced current source design. A current mode driver, has a high output impedance and supplies a constant current for a range of loads (a voltage mode driver on the other hand supplies a constant voltage for a range of loads). Current is switched through the load in one direction to produce a logic state and in the other direction to produce the other logic state. The current mode **requires** (as discussed above) that a resistive termination be employed to terminate the signal and to complete the loop as shown in Figure 3. AC or unterminated configurations are not allowed. The 3.4mA loop current will develop a differential voltage of 340mV across the 100Ω termination resistor which the receiver detects with a 240mV minimum differential noise margin neglecting resistive line losses (driven signal minus receiver threshold (340mV - 100mV = 240mV)). The signal is centered around +1.2V (Driver Offset, V_{OS}) with respect to ground as shown in Figure 4. **Note:** The steady-state voltage (V_{SS}) peak-to-peak swing is twice the differential voltage (V_{OD}) and is typically 680mV.



Note: The footprint of the UT54LVDS031LV is the same as the industry standard Quad Differential (RS-422) Driver.

Figure 4. Driver Output Levels

The current mode driver provides substantial benefits over voltage mode drivers, such as an RS-422 driver. Its quiescent current remains relatively flat versus switching frequency. Whereas the RS-422 voltage mode driver increases exponentially in most cases between 20 MHz - 50 MHz. This is due to the overlap current that flows between the rails of the device when the internal gates switch. Whereas the current mode driver switches a fixed current between its output without any substantial overlap current. This is similar to some ECL and PECL devices, but without the heavy static I_{CC} requirements of the ECL/PECL design. LVDS requires 80% less current than similar PECL devices. AC specifications for the driver are a tenfold improvement over other existing RS-422 drivers.

The Three-State function allows the driver outputs to be disabled, thus obtaining an even lower power state when the transmission of data is not required.

OPERATIONAL ENVIRONMENT

PARAMETER	LIMIT	UNITS
Total Ionizing Dose (TID)	1.0E6	rad(Si)
Single Event Latchup (SEL)	>100	MeV-cm ² /mg
Neutron Fluence ¹	1.0E13	n/cm ²

Notes:1. Guaranteed but not tested.

ABSOLUTE MAXIMUM RATINGS¹

(Referenced to V_{SS})

SYMBOL	PARAMETER	LIMITS
V _{DD}	DC supply voltage	-0.3 to 4.0V
V _{I/O}	Voltage on any pin during operation	-0.3 to (V _{DD} + 0.3V)
	Voltage on any pin during cold spare	-.3 to 4.0V
T _{STG}	Storage temperature	-65 to +150°C
P _D	Maximum power dissipation	1.25 W
T _J	Maximum junction temperature ²	+150°C
Θ _{JC}	Thermal resistance, junction-to-case ³	10°C/W
I _I	DC input current	±10mA

Notes:

1. Stresses outside the listed absolute maximum ratings may cause permanent damage to the device. This is a stress rating only, and functional operation of the device at these or any other conditions beyond limits indicated in the operational sections of this specification is not recommended. Exposure to absolute maximum rating conditions for extended periods may affect device reliability and performance.
2. Maximum junction temperature may be increased to +175°C during burn-in and life test.
3. Test per MIL-STD-883, Method 1012.

RECOMMENDED OPERATING CONDITIONS

SYMBOL	PARAMETER	LIMITS
V _{DD}	Positive supply voltage	3.0 to 3.6V
T _C	Case temperature range	-55 to +125°C
V _{IN}	DC input voltage	0V to V _{DD}

DC ELECTRICAL CHARACTERISTICS*1, 2

($V_{DD} = 3.3V \pm 0.3V$; $-55^{\circ}C < T_C < +125^{\circ}C$); Unless otherwise noted, T_c is per the temperature range ordered

SYMBOL	PARAMETER	CONDITION	MIN	MAX	UNIT
V_{IH}	High-level input voltage	(TTL)	2.0	V_{DD}	V
V_{IL}	Low-level input voltage	(TTL)	V_{SS}	0.8	V
V_{OL}	Low-level output voltage	$R_L = 100\Omega$	0.925		V
V_{OH}	High-level output voltage	$R_L = 100\Omega$		1.650	V
I_{IN}	Input leakage current	$V_{IN} = V_{DD}$ or GND, $V_{DD} = 3.6V$	-10	+10	μA
I_{CS}	Cold Spare Leakage Current	$V_{IN}=3.6V, V_{DD}=V_{SS}$	-20	+20	μA
V_{OD}^1	Differential Output Voltage	$R_L = 100\Omega$ (figure 5)	250	400	mV
ΔV_{OD}^1	Change in Magnitude of V_{OD} for Complementary Output States	$R_L = 100\Omega$ (figure 5)		35	mV
V_{OS}	Offset Voltage	$R_L = 100\Omega, \left(V_{OS} = \frac{V_{OH} + V_{OL}}{2} \right)$	1.125	1.450	V
ΔV_{OS}	Change in Magnitude of V_{OS} for Complementary Output States	$R_L = 100\Omega$ (figure 5)		25	mV
V_{CL}^3	Input clamp voltage	$I_{CL} = +18mA$	-1.5		V
$I_{OS}^{2,3}$	Output Short Circuit Current	$V_{IN} = V_{DD}, V_{OUT+} = 0V$ or $V_{IN} = GND, V_{OUT-} = 0V$		9.0	mA
I_{OZ}^3	Output Three-State Current	$EN = 0.8V$ and $\overline{EN} = 2.0V$, $V_{OUT} = 0V$ or $V_{DD}, V_{DD} = 3.6V$	-10	+10	μA
I_{CCL}^3	Loaded supply current, drivers enabled	$R_L = 100\Omega$ all channels $V_{IN} = V_{DD}$ or V_{SS} (all inputs)		18.0	mA
I_{CCZ}^3	Loaded supply current, drivers disabled	$D_{IN} = V_{DD}$ or V_{SS} $EN = V_{SS}, \overline{EN} = V_{DD}$		3.0	mA

Notes:

* For devices procured with a total ionizing dose tolerance guarantee, the post-irradiation performance is guaranteed at $25^{\circ}C$ per MIL-STD-883 Method 1019, Condition A up to the maximum TID level procured.

1. Current into device pins is defined as positive. Current out of device pins is defined as negative. All voltages are referenced to ground except differential voltages.
2. Output short circuit current (I_{OS}) is specified as magnitude only, minus sign indicates direction only.
3. Guaranteed by characterization.

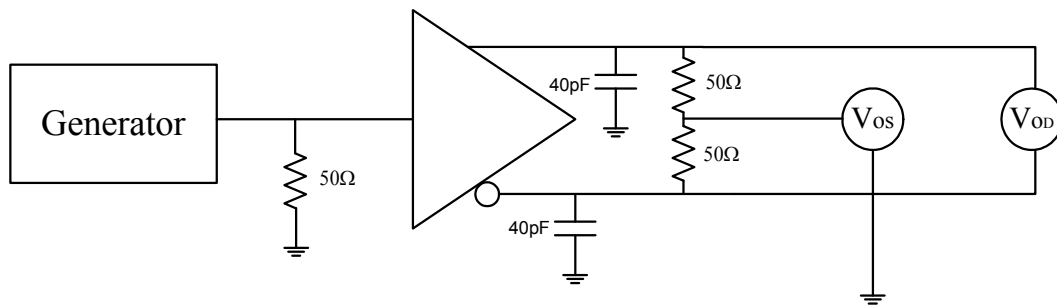

Figure 5. Driver V_{OD} and V_{OS} Test Circuit or Equivalent Circuit

AC SWITCHING CHARACTERISTICS*1, 2, 3

($V_{DD} = +3.3V \pm 0.3V$, $T_C = -55\text{ }^\circ\text{C}$ to $+125\text{ }^\circ\text{C}$); Unless otherwise noted, T_c is per the temperature range ordered

SYMBOL	PARAMETER	MIN	MAX	MIN	MAX	UNIT
		UT54LVDS031LV		UT54LVDS031LVE		
t_{PHLD}	Differential Propagation Delay High to Low (figures 6 and 7)	0.3	3.0	0.8	1.5	ns
t_{PLHD}	Differential Propagation Delay Low to High (figures 6 and 7)	0.3	3.0	0.8	1.5	ns
t_{SKD}	Differential Skew ($t_{PHLD} - t_{PLHD}$) (figures 6 and 7)	0	400	0	310	ps
t_{SK1}	Channel-to-Channel Skew ¹ (figures 6 and 7)	0	500	0	280	ps
t_{SK2}	Chip-to-Chip Skew ⁵ (figure 6 and 7)		2.7		0.7	ns
t_{TLH} ⁴	Rise Time (figures 6 and 7)		1.5		0.6	ns
t_{THL} ⁴	Fall Time (figures 6 and 7)		1.5		0.6	ns
t_{PHZ}	Disable Time High to Z (figures 8 and 9)		5.0		2.8	ns
t_{PLZ}	Disable Time Low to Z (figures 8 and 9)		5.0		2.8	ns
t_{PZH}	Enable Time Z to High (figures 8 and 9)		7.0		2.5	ns
t_{PZL}	Enable Time Z to Low (figures 8 and 9)		7.0		2.5	ns

Notes:

* For devices procured with a total ionizing dose tolerance guarantee, the post-irradiation performance is guaranteed at 25°C per MIL-STD-883 Method 1019, Condition A up to the maximum TID level procured.

1. Channel-to-Channel Skew is defined as the difference between the propagation delay of the channel and the other channels in the same chip with an event on the inputs.

2. Generator waveform for all tests unless otherwise specified: $f = 1\text{ MHz}$, $Z_O = 50$, $t_r \leq 1\text{ ns}$, and $t_f \leq 1\text{ ns}$.

3. C_L includes probe and jig capacitance.

4. Guaranteed by characterization

5. Chip to Chip Skew is defined as the difference between the minimum and maximum specified differential propagation delays.

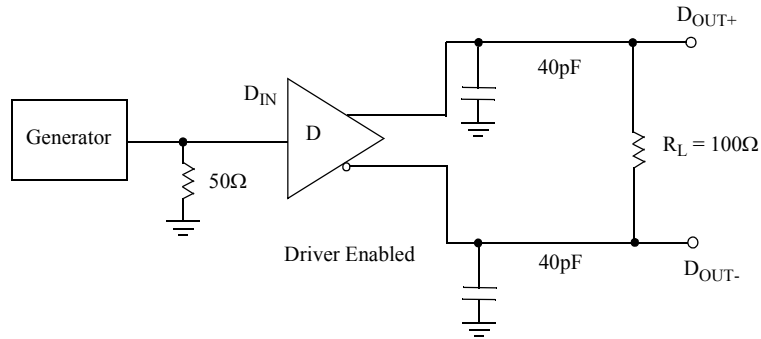

Figure 6. Driver Propagation Delay and Transition Time Test Circuit or Equivalent Circuit

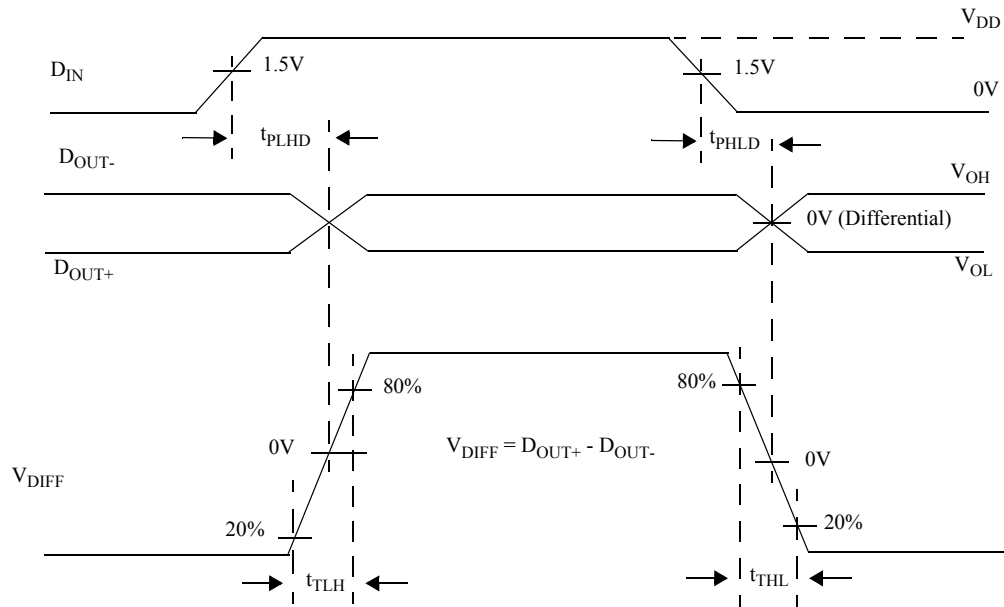

Figure 7. Driver Propagation Delay and Transition Time Waveforms

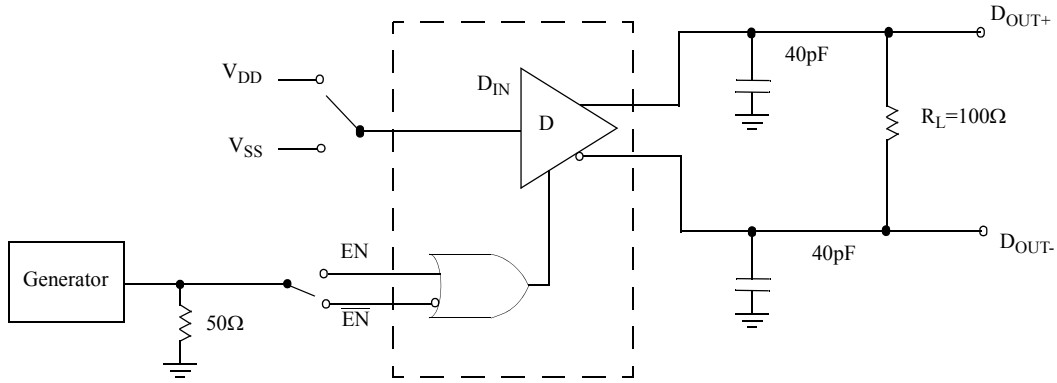

Figure 8. Driver Three-State Delay Test Circuit or Equivalent Circuit

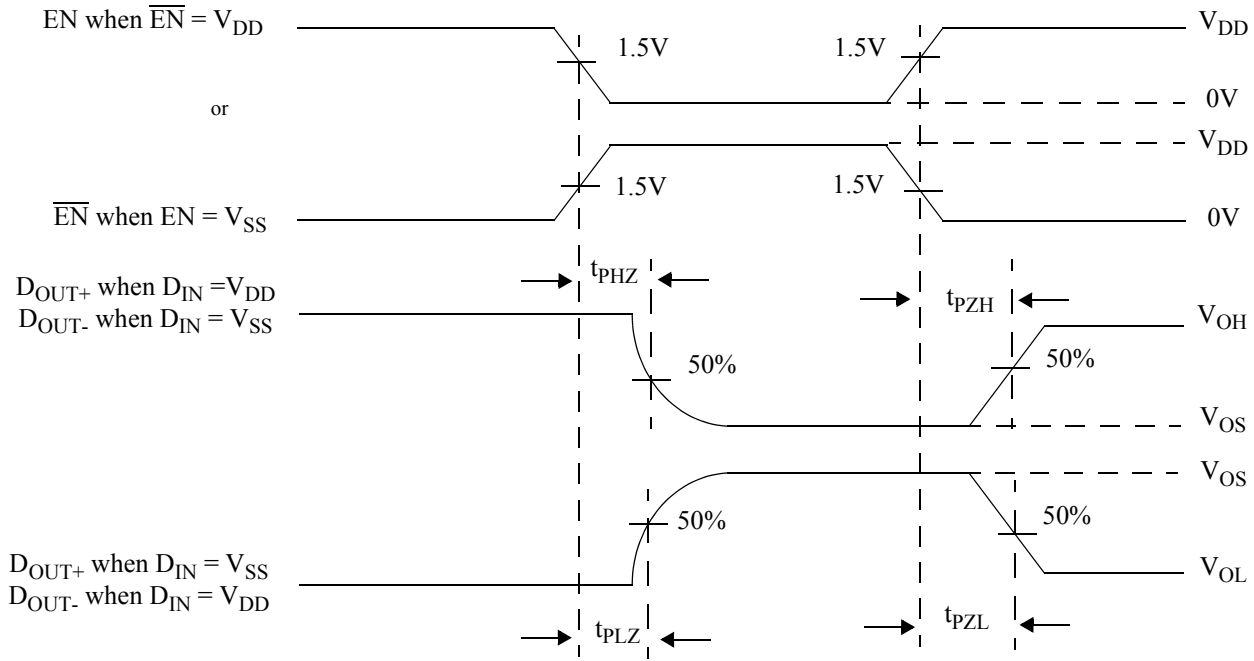
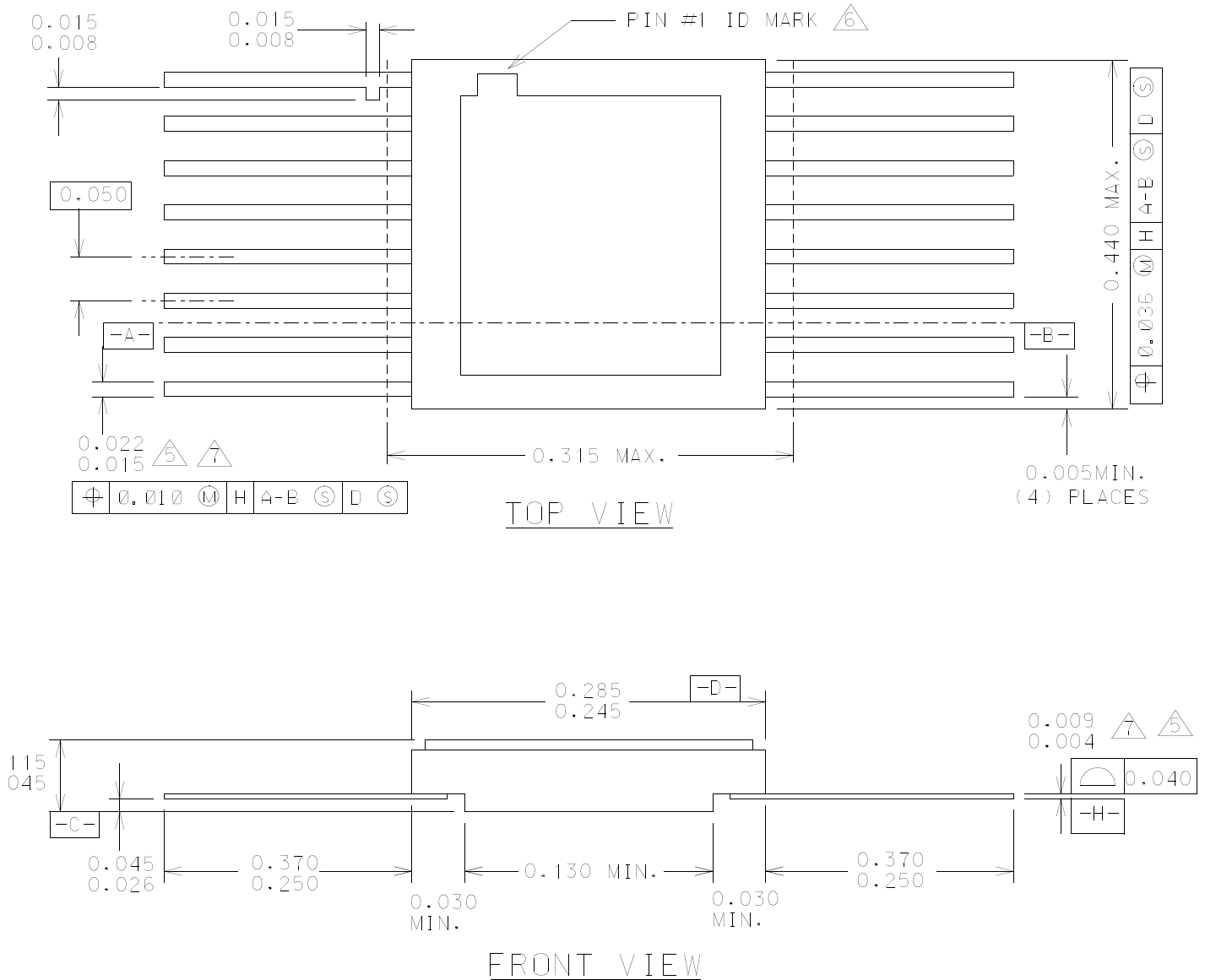

Figure 9. Driver Three-State Delay Waveform

PACKAGING



Notes:

1. All exposed metalized areas are gold plated over electroplated nickel per MIL-PRF-38535.
 2. The lid is electrically connected to VSS.
 3. Lead finishes are in accordance to MIL-PRF-38535.
 4. Package dimensions and symbols are similar to MIL-STD-1835 variation F-5A.
- △ Lead position and coplanarity are not measured.
 △ ID mark symbol is vendor option.
 △ With solder, increase maximum by 0.003.

Figure 10. 16-pin Ceramic Flatpack

ORDERING INFORMATION

UT54LVDS031LV/E QUAD DRIVER:

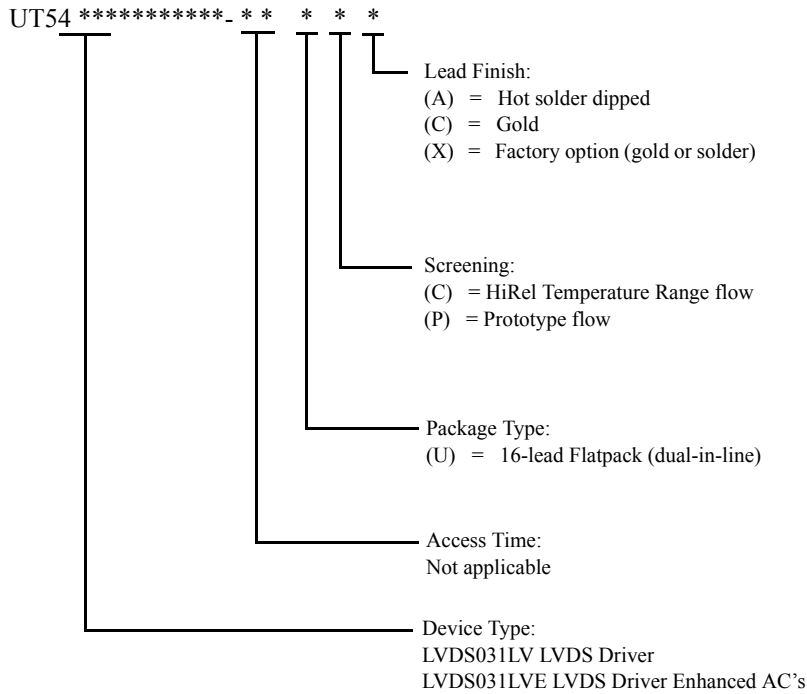

Notes:

1. Lead finish (A,C, or X) must be specified.
2. If an "X" is specified when ordering, then the part marking will match the lead finish and will be either "A" (solder) or "C" (gold).
3. Prototype flow per Aeroflex Manufacturing Flows Document. Tested at 25°C only. Lead finish is GOLD ONLY. Radiation neither tested nor guaranteed.
4. HiRel Temperature Range flow per Aeroflex Manufacturing Flows Document. Devices are tested at -55°C, room temp, and 125°C. Radiation neither tested nor guaranteed.

UT54LVDS031LV/E QUAD DRIVER: SMD

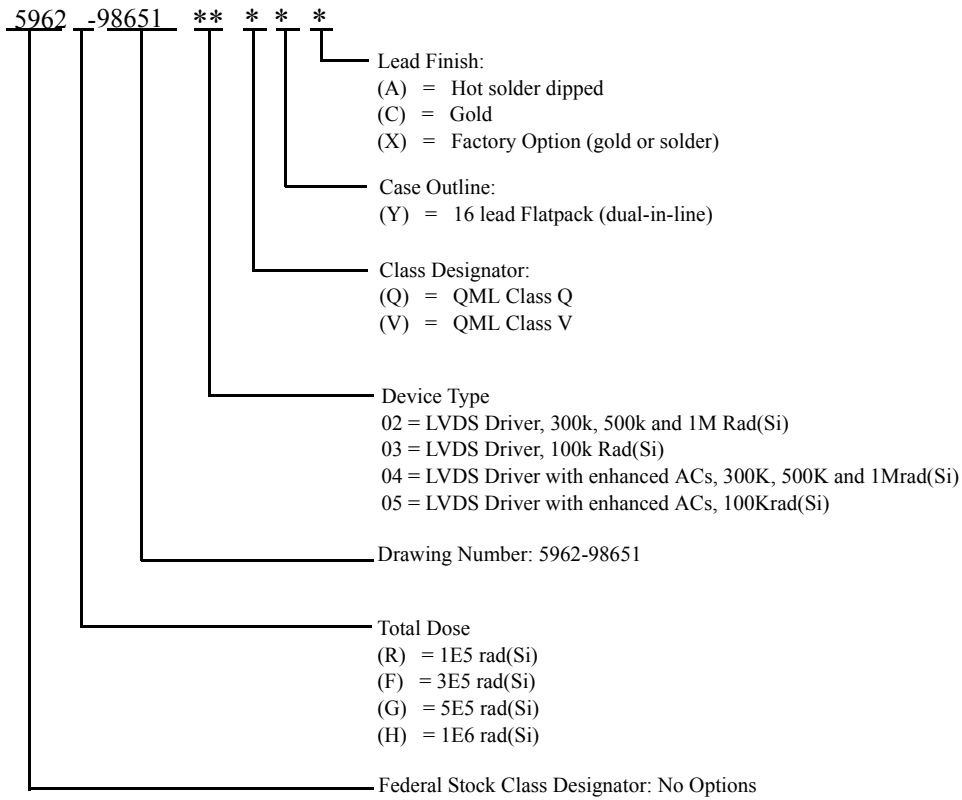

Notes:

1. Lead finish (A, C, or X) must be specified.
2. If an "X" is specified when ordering, part marking will match the lead finish and will be either "A" (solder) or "C" (gold).
3. Total dose radiation must be specified when ordering. QML Q and QML V not available without radiation hardening.

Aeroflex Colorado Springs - Datasheet Definition

Advanced Datasheet - Product In Development

Preliminary Datasheet - Shipping Prototype

Datasheet - Shipping QML & Reduced Hi-Rel

COLORADO

Toll Free: 800-645-8862
Fax: 719-594-8468

INTERNATIONAL

Tel: 805-778-9229
Fax: 805-778-1980

NORTHEAST

Tel: 603-888-3975
Fax: 603-888-4585

SE AND MID-ATLANTIC

Tel: 321-951-4164
Fax: 321-951-4254

WEST COAST

Tel: 949-362-2260
Fax: 949-362-2266

CENTRAL

Tel: 719-594-8017
Fax: 719-594-8468

www.aeroflex.com info-ams@aeroflex.com

Aeroflex Colorado Springs, Inc. reserves the right to make changes to any products and services herein at any time without notice. Consult Aeroflex or an authorized sales representative to verify that the information in this data sheet is current before using this product. Aeroflex does not assume any responsibility or liability arising out of the application or use of any product or service described herein, except as expressly agreed to in writing by Aeroflex; nor does the purchase, lease, or use of a product or service from Aeroflex convey a license under any patent rights, copyrights, trademark rights, or any other of the intellectual rights of Aeroflex or of third parties.



Our passion for performance is defined by three attributes represented by these three icons: solution-minded, performance-driven and customer-focused