

# Standard Products

## UT699 Single Board Computer

Fact Sheet

May, 2012

www.aeroflex.com/LEON



### OVERVIEW

Off-the-shelf 3U cPCI form factor Single Board Computer (SBC) based on the UT699 LEON 3FT 32-bit SPARC™ V8 Microprocessor. The UT699 SBC addresses size (160mm x 100mm), weight (<4 pounds) and power (<5.5W). The UT699 SBC has a path to flight (non-flight and flight variants to be available). The UT699 SBC includes an FPGA, volatile and non-volatile memory, 10 user defined A/D channels, 192 pin mezzanine connector (1) and the following interfaces: SpW (4), USB (1), cPCI 33MHz/32bit (1), JTAG (1), 10/100 Ethernet (1) for terrestrial use. The non-flight UT699 SBC is also available in the ALEXIS (Aeroflex LEON Experimenter's Interface System) development platform.

### FEATURES

- ❑ Proven microprocessor technology
  - Based on the UT699 LEON 3FT 32-bit SPARC™ V8 Microprocessor
  - UT699 at 66MHz, 89 DMIPs throughput
  - Flight heritage
  - Industry standard development tools; real-time software operating system support
- ❑ Addresses size, weight and power (SWaP)
  - Size: Small, 3U cPCI form factor, 160mm x 100mm
  - Weight: 3.8 lbs (Estimate)
  - Power: <5.5W

- ❑ Development prototype version consists of the following:
  - One (1) UT699 LEON 3FT Microprocessor
  - One (1) Xilinx Virtex-4 LX100 support FPGA
  - 8MB of non-volatile memory organized into 2Mx32
  - 64MB of SDRAM organized into 4M x 32 x 4 banks
  - 16MB of SRAM organized into 2M x 32
  - One (1) RS-422 UART interface
  - Four (4) ECSS-E-50-12A standard SpaceWire (SpW) ports
  - One (1) 10/100M Ethernet ports
  - One (1) 33MHz/32-bit standard cPCI interface
  - One (1) JTAG interface for programming and debug of UT699 LEON3FT
  - One (1) 192-pin mezzanine card expansion connectors
  - Ten (10) user defined A/D channels (0 to 2.5 VDC)

### PATH TO FLIGHT

- ❑ Flight unit is drop-into the prototype version with appropriate changes to component selection for guaranteed radiation performance
- ❑ Environmentally hardened parts (i.e. UT6325 Eclipse RadTol FPGA)
  - De-population of Ethernet port
- ❑ Customized versions available (examples: 6U SBC with more memory, 3U SBC with different interface mix, specific mezzanine cards for plug into SBC i.e.1553 mezzanine)

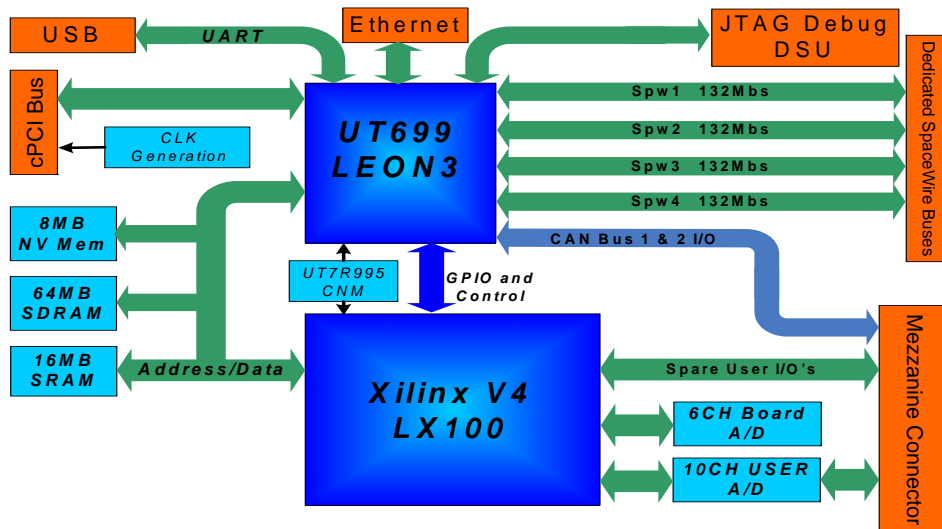

Figure 1: UT699 SBC Block Diagram

Standard Products  
**ALEXIS Development System**

Fact Sheet

November, 2011

[www.aeroflex.com/LEON](http://www.aeroflex.com/LEON)



**OVERVIEW**

- ❑ ALEXIS stands for Aeroflex LEON Experimenter's Interface System, which is a self-contained Development Platform that comes with Hardware and Software Components
- ❑ ALEXIS is a ready to run Development Platform with a flexible architecture to support a variety of customer applications
- ❑ ALEXIS decreases development time and user learning curve
- ❑ ALEXIS comes with a non-flight UT699 Single Board Computer (SBC) which has a path to flight

**FEATURES**

- ❑ Self-contained 3UcPCI Chassis
- ❑ Includes an off-the-shelf 3U cPCI UT699 SBC, with the following highlights:
  - UT699 LEON 3FT 32-bit SPARC™ V8 Microprocessor; 66 MHz, 89 DMIPS
  - Weight <4 pounds; Power <5.5W
  - Includes a reconfigurable FPGA, volatile and non-volatile memory, 10 user defined A/D channels, and 192-pin mezzanine connectors (2)
  - Includes the following interfaces: SpW (4), USB (1), cPCI 33MHz/32bit (1), JTAG (1), UT699 LEON Debug Port (1), 10/100 Ethernet (1)

- ❑ The UT699 SBC operates as a system control board and provides 33MHz cPCI Clocks and bus arbitration
- ❑ Completely self-contained unit with a power card. Provides additional user cPCI backplane power (5V @ 2A, 3.3V @ 3A), generates cPCI Power-up Reset (3.3V level, 200mS).
- ❑ Includes a Touch Screen Display/ Video Interface Card which offloads processing from the UT699 to the Mezzanine Card
  - Includes an embedded 32-bit RISC video processor
  - 4.3 inch touch screen display with external USB I/F
  - Demonstrations and preloaded operating systems and drivers can be selected using the Touch Screen
  - Includes preloaded operating systems and application drivers. OS options include: LINUX, RTEMS, VxWorks. Driver options include: drivers for SpW, Ethernet, cPCI Host
- ❑ Includes two (2) open cPCI slots for future/customer designed cards such as: SpaceWire Router, Telemetry, 1553, A/D
- ❑ Customer software can be loaded onto the ALEXIS via USB interface port and GRMOM (available from Aeroflex Gaisler) into the single board computer's main NV, SRAM or SDRAM memory
- ❑ GRMON and a Xilinx USB JTAG pod are required for ALEXIS software development



**Figure 1: ALEXIS**

# *Aeroflex Colorado Springs - Datasheet Definition*

**Advanced Datasheet - Product In Development**

**Preliminary Datasheet - Shipping Prototype**

**Datasheet - Shipping QML & Reduced Hi-Rel**

**COLORADO**

Toll Free: 800-645-8862  
Fax: 719-594-8468

**INTERNATIONAL**

Tel: 805-778-9229  
Fax: 805-778-1980

**NORTHEAST**

Tel: 603-888-3975  
Fax: 603-888-4585

**SE AND MID-ATLANTIC**

Tel: 321-951-4164  
Fax: 321-951-4254

**WEST COAST**

Tel: 949-362-2260  
Fax: 949-362-2266

**CENTRAL**

Tel: 719-594-8017  
Fax: 719-594-8468

*[www.aeroflex.com](http://www.aeroflex.com)    [info-ams@aeroflex.com](mailto:info-ams@aeroflex.com)*

Aeroflex Colorado Springs, Inc., reserves the right to make changes to any products and services herein at any time without notice. Consult Aeroflex or an authorized sales representative to verify that the information in this data sheet is current before using this product. Aeroflex does not assume any responsibility or liability arising out of the application or use of any product or service described herein, except as expressly agreed to in writing by Aeroflex; nor does the purchase, lease, or use of a product or service from Aeroflex convey a license under any patent rights, copyrights, trademark rights, or any other of the intellectual rights of Aeroflex or of third parties.



Our passion for performance is defined by three attributes represented by these three icons: solution-minded, performance-driven and customer-focused