

Application Note



Interpretation of Fault Location Results Using the 6820 series Scalar Analyzers



Typical causes of degraded return loss measurements on transmission lines and antennas are examined. Good measurement techniques are explained and useful hints provided for users of the 6820 series scalar analyzer in the field

Introduction

The powerful fault location facility of the 6820 series scalar analyzers allows the user to locate faults in cables

or waveguide systems to high accuracy.

Fault location provides a means of measuring VSWR or Return Loss in real time as a function of distance. The

system identifies the location of any faults or discontinuities to an accuracy of 0.1% of range. For a 100 metre (328 feet) cable, a fault will be determined to within 10 centimetres (4 inches) of its true position.

Why do faults cause reflections?

In any microwave system, reflections are caused whenever a microwave signal encounters an impedance discontinuity.

If we take a normal system with an impedance, Z_0 of 50Ω , then figure 1 below illustrates the effect.

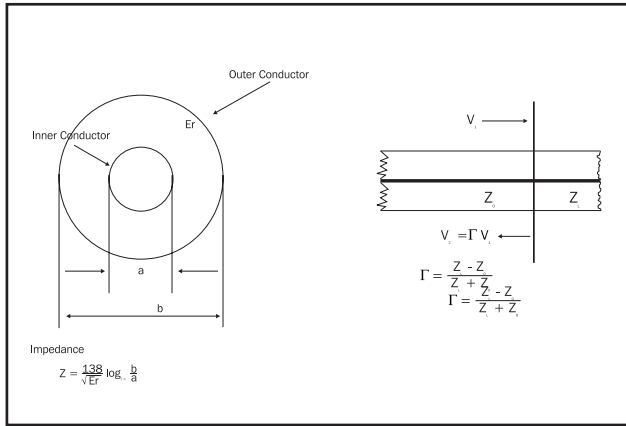

Figure 1 - Impedance of coaxial transmission line

If a microwave signal travels for a transmission line of impedance Z_0 into a line of impedance Z_L , part of the signal will be reflected.

The ratio of the amount of signal reflected (V_2) to the amount of signal incident on the discontinuity (V_1) is termed reflection coefficient, Γ , where:

$$\Gamma = V_2/V_1$$

Reflection coefficient can also be expressed in terms of two different impedances:

$$\Gamma = \frac{Z_L - Z_0}{Z_L + Z_0}$$

and if Z_0 is 50Ω , then:

$$\Gamma = \frac{Z_L - 50}{Z_L + 50}$$

By looking at this equation it is clear that the larger the difference between Z_L and 50Ω , the greater the reflection coefficient, Γ .

For a coaxial line, the impedance is dependent on the diameter of the centre conductor (a), the outer conductor (b), and the dielectric constant of the material used in the line ϵ_r . Any alteration to

any of these dimensions will cause a change in impedance and will result in some signal being reflected.

It is more usual to use return loss and VSWR to define the magnitude of reflections rather than reflection coefficient. However, return loss, VSWR and reflection coefficient are all different ways of defining the same parameter and they are related by the following equations:

$$VSWR = \frac{1 + |\Gamma|}{1 - |\Gamma|}$$

$$|\Gamma| = \frac{VSWR - 1}{VSWR + 1}$$

$$Return Loss = -20 \log_{10} |\Gamma| dB$$

Table 1 (see back page) shows the relationship between return loss, VSWR and reflection coefficient.

An antenna would typically be specified over, for example, a 100 MHz bandwidth to have a return loss of about 20 dB or better.

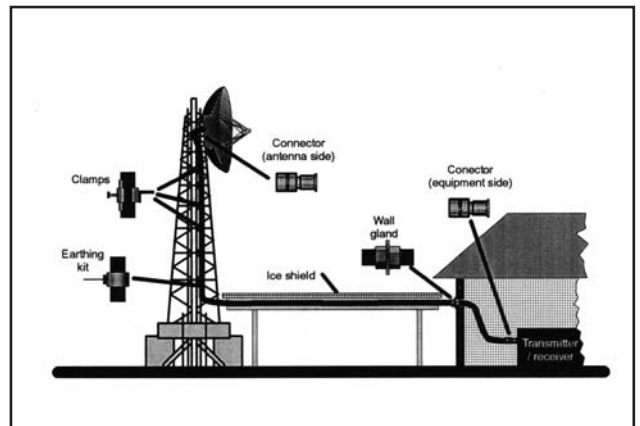

Figure 2 - Typical transceiver/antenna system.

Figure 2 shows a generalised transceiver/antenna system. The basic components are a transceiver, a cable (or waveguide) and an antenna. A typical fault location response is shown in figure 3.

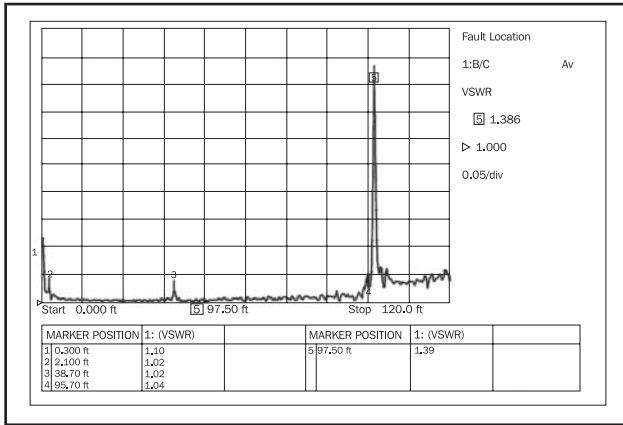

Figure 3 - Fault location measurement on a 7 GHz transmit chain.

The measurement was made on a 7 GHz transmit chain with an elliptical waveguide of 30 metres (98 feet) terminated with a narrow band antenna optimised at 7 GHz. The particular antenna in question was damaged and a clear fault can be seen at 29.7 metres (97.5 feet).

- Marker 1 - Indicates the position of the test port/waveguide adapter interface - there is inevitably a mismatch at this point, normally with a VSWR between 1.05 and 1.15.
- Marker 2 - Indicates the position of the interface between the jumper cable and the main cable - the VSWR at this point should be less than 1.05, i.e. about the value expected from a good quality connector.
- Marker 3 - Indicates a small discontinuity in the waveguide run. This is probably a result of a slight dent in the waveguide and is on the limit of acceptability.
- Marker 4 - Indicates an elliptical waveguide to flexible waveguide interface.
- Marker 5 - Indicates the position of the antenna - the antenna is not well matched as a VSWR of 1.4:1 is relatively high.

There are a wide variety of possible faults which may occur along an antenna feed. In order to identify the effect of the faults on the system, it is necessary to perform fault location measurements in conjunction with either a return loss or insertion loss measurement. The next section shows some examples of common faults.

Examples of Common Faults

1) Antenna Faults

Generally, antenna faults can be divided into two categories. Firstly, faults with the antenna itself (usually due to damage to the antenna) and secondly, faults due to the antenna being connected incorrectly to the cable/waveguide system.

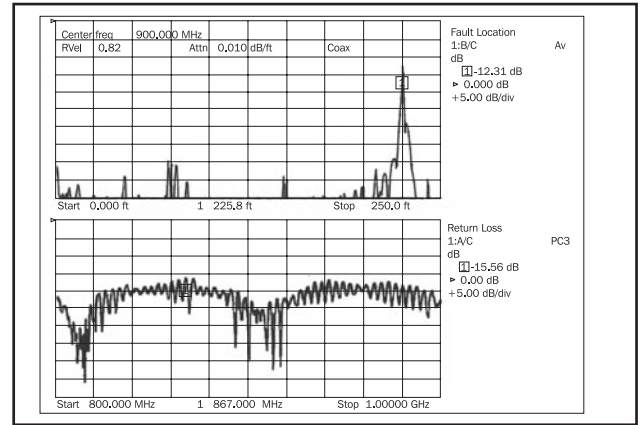

Figure 4 - Dual return loss and fault location measurement on a coaxial system terminated with a damaged antenna.

Figure 4 shows a return loss and fault location measurement of a coaxial system terminated with a damaged antenna.

The particular system shown operates in the UHF cellular band. The system should exhibit a return loss of better than 23 dB between 855 and 890 MHz, but the lower plot shows that the return loss averages about 18 dB in this band and is as bad as 15 dB in places. The fault location plot clearly indicates the fault as being at the antenna, the return loss at this point being about 12 dB. (The reason why the return loss appears worse in the fault location plot compared with the return loss plot is that the attenuation of the cable is taken into account in the fault location plot. In the return loss plot, the test port where the measurement is made is at the transceiver end of the cable and so a fault in the antenna will appear less severe than it really is by twice the attenuation of the cable. In this example, the attenuation of the cable is 2.5 dB and so a fault in the antenna causing us to measure a return loss of 18 dB really has a return loss of 13 dB).

Note, on the return loss plot that the ripple on the response repeats every 2 - 3 MHz. As a general rule, the "faster" the ripple, the further the fault lies from the test port.

Typically, from a narrowband antenna, one would expect to see a return loss of about 20 dB (for a wideband antenna, a return loss of 15 dB is more normal). Examining figure 5 below shows the same system with the damaged antenna replaced by a known good antenna. The average return loss in the operating band is better than 30 dB and an examination of the fault location response shows a 20 dB improvement in the return loss of the antenna.

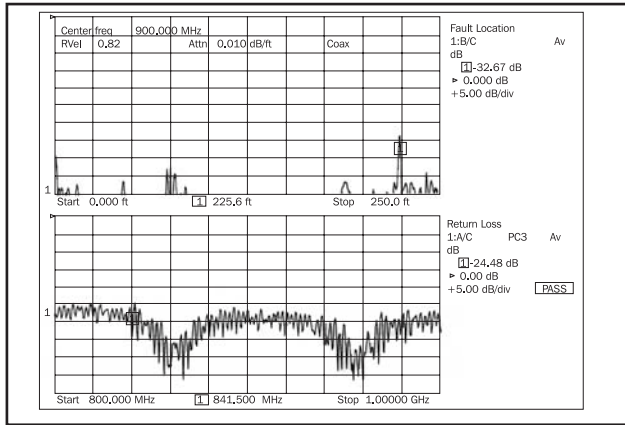

Figure 5 - The same system as displayed in figure 4 but with the antenna repaired.

2) Connector Faults

Connectors are probably the most problematic component within a cable system, both in terms of frequency of faults and in terms of detection. Figure 6 shows a connector fault at the interface between a 2 metre (6.5 feet) jumper cable and the main cable run.

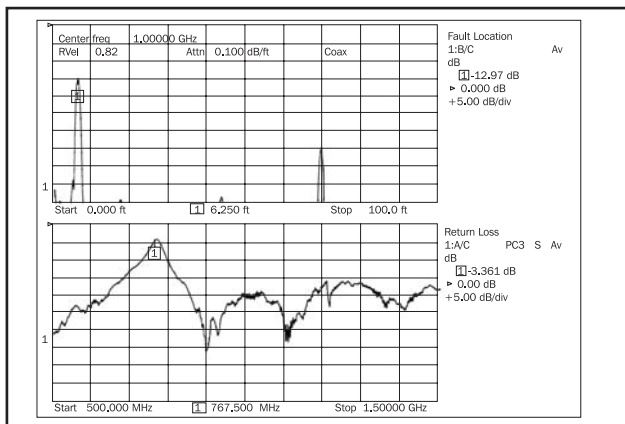

Figure 6: Fault location and return loss plot shows a connection fault at 1.9 metres from the start of the cable run.

Examining the plot, the frequency dependent nature of the fault becomes evident. Connector faults tend to result in small gaps in the microwave transmission line and resonances are set up which reflect the incident power back towards the transceiver. The frequency of a connector resonance is dependent on the width of these gaps. In this particular case, there is a severe fault at about 750-800 MHz with a worst case return loss of 3.36 dB. This means that at a frequency of 767 MHz nearly half the incident power is being reflected. The fault location plot shows a fault at 1.9 metres (6.2 feet), with a return loss of 13 dB and this shows the danger of making a fault location measurement on its own. The problem is that fault location is a composite frequency measurement, i.e. it takes an average of all the different frequencies used in a return loss measurement. The problem that results from this is that a fault producing a high return loss at one individual frequency or a narrow frequency band appears less bad than it really is. The effect of a bad return loss over a narrow band is averaged with frequencies where the return loss is not as bad.

This is why it is essential to perform both a fault location measurement AND a return loss measurement.

It is also worth noting on the return loss plot that there is a very small fast ripple (due to the antenna at the end of the cable) and a much larger slow ripple because the fault is relatively close to the test port. The peak on the fault location plot at 21 metres (69 feet) shows the position of the antenna.

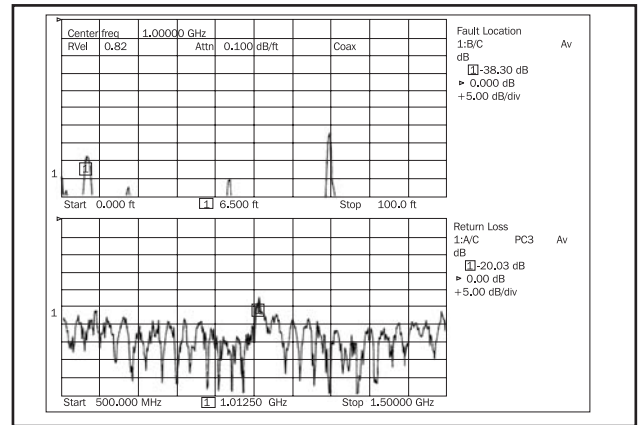

Figure 7: The same system as displayed in figure 6 but with the connector fault correction.

Figure 7 shows the same link as plotted in figure 6 where the connector fault was corrected - the return loss is generally about 25-30 dB and the slow ripple has disappeared. Similarly the peak on the fault location plot at 1.9 metres (6.2 feet) is vastly reduced.

Another common connector fault is ingress of water into the connector. Remembering that the impedance of a coaxial cable or waveguide is dependent on the dielectric constant, ϵ_r , and knowing that water has an ϵ_r of between 70 and 100 (ϵ_r for air = 1 and most dielectrics have an ϵ_r between 2 and 4) it is clear that the impedance will alter dramatically if water seeps into the connector. The fault will appear as a general deterioration of return loss as opposed to the narrow band deterioration seen in other connector faults and as a peak at the connector location in a fault location measurement.

3) Cable Faults

Cable faults are highly variable and, unsurprisingly, the effect on return loss and fault location plots depends on how much damage has been caused to the cable. A general rule of thumb is that any peak on a fault location plot showing a return loss of worse than 30 dB where no known connector or cable splice is present should be viewed with suspicion. In the example shown in figure 8, the return loss measurement shows a worst case performance of 21 dB and in the operating band (800 - 900 MHz), the return loss is about 30 dB which for most cellular systems would be within specification. Clearly a cable with an open circuit should not pass a specification test! This, however, illustrates the weakness of return loss measurements - if the cable is extremely poor and the fault is a long distance from the test port, the loss can be so great as to disguise the true nature of the fault. In this particular example, the fault is 76 metres (250 feet) from the test port and the cable attenuation is 0.2 dB/metre. A signal will be attenuated by $76 \times 0.2 = 15$ dB. Therefore an open circuit line will show a return loss of 30 dB.

The message here is that it is essential to perform both return loss and fault location measurements.

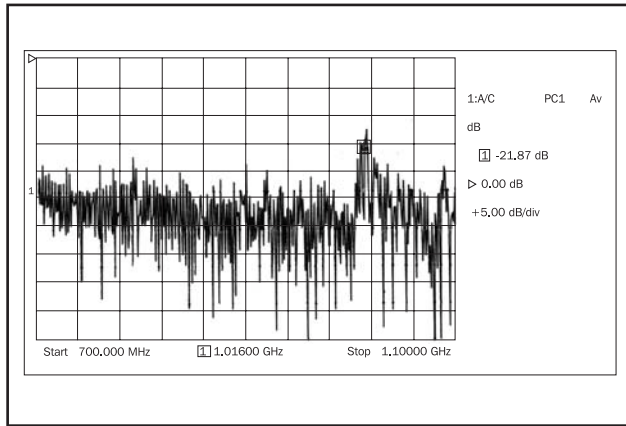

Figure 8: Return loss measurement on a cable showing worst case performance of approximately 22 dB

Do's and Don'ts

As with any RF or Microwave measurement there are a number of things to be careful about:

1) Waveguide fault location

a) The 6820 series scalar analyzer calculates the relative velocity at each frequency internally from knowledge of the cut-off frequency. The cut-off frequency must therefore be entered as accurately as can be obtained from the waveguide manufacturers data. Incorrect cut-off frequency values are the biggest single cause of erroneous results. Entering an incorrect cut-off frequency makes the scalar analyzer calculate the relative velocity at each frequency incorrectly and hence the distance appears in error.

b) Use a waveguide directional coupler for return loss measurements. Making return loss measurements with a coaxial return loss bridge and waveguide/coaxial adapter degrades measurement accuracy. The problem is that the adapters degrade the effective directivity of the bridge to the point where it can become unusable.

2) General Points

a) Always ensure the centre frequency and bandwidth are correct - this may sound obvious but there are a number of subtleties in choosing an adequate bandwidth. Most antennas have a performance specified over a limited frequency range. For example, a typical cellular antenna will exhibit a return loss of about 25-30 dB between 800 and 900 MHz but its performance at say, 600 MHz or 1100 MHz may be much worse. The reason why this sometimes creates a problem in fault location is that the range is inversely proportional to the bandwidth required. That is to say that for short cable runs (less than 15 metre) a large operating bandwidth is required (several hundred MHz). As mentioned before, fault location measurements take the average of the return loss at each frequency point. Therefore if we use a 500 MHz bandwidth centred on a 850 MHz to measure a cellular antenna we will measure the return loss at the antenna as being much worse than it really is. This is because the good perform-

ance of the antenna between 750 and 950 MHz is averaged with poor performance outside the frequency range.

There is only one solution to the above problem. The bandwidth required is inversely proportional to the number of points. Thus, if initial settings show a bandwidth of 400 MHz is required for a particular range, reducing the number of points for 401 to 201 will halve the required bandwidth to 200 MHz.

b) Select windowing to clarify displays: as a consequence of the processing involved in fault location the discontinuity appears on the display as a peak with no associated ripple. Figure 9 demonstrates this effect. With minimum windowing there is a substantial ripple which may obscure an adjacent fault of smaller magnitude. The ripple may be reduced by applying windowing. The other trace shows the same measurement with maximum windowing applied. This has all but eliminated the ripple but does have the undesirable side-effect of broadening the peak. Generally speaking, medium windowing is best for most applications.

c) Ensure the correct range is selected: this means selecting a range greater than the length of the cable run. The big problem is aliasing. This means that if the range is too short, peaks outside the measurement range will appear as aliased peaks at the wrong distance. Inevitably confusion can arise. Always set the ranges to be 25 % longer than the cable - once the true distance to the fault has been established the range can be reduced by use of the "Zoom" mode within the 6820 series menu.

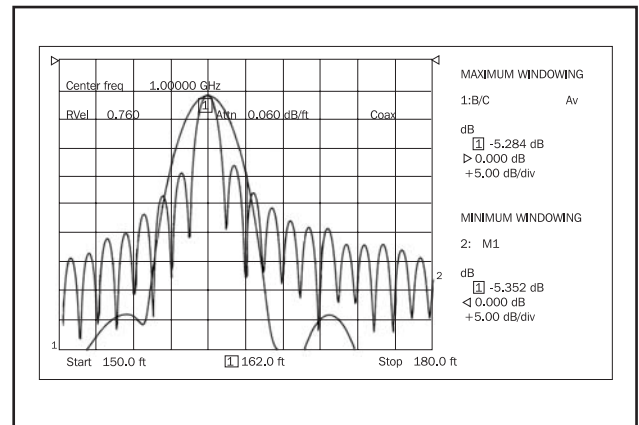

Figure 9 - Use of windowing to minimise sidelobes.

d) Interference - what can we do? One of the biggest problems faced in both fault location and return loss measurements is interference from adjacent transmitters. There are four things to do:

i) Use AC detection - this modulates the RF output of the 6820 series with a square wave and makes two measurements at each frequency - one with RF switched on and one with RF switched off. Then:

$$Pwr\ RF\ on = Measurement + Interference$$

$$Pwr\ RF\ off = Interference$$

Pwr on - Pwr off = Measurement only

- (ii) Set output power to its highest level.
- (iii) Use averaging to average out interference
- (iv) Steps (i), (ii) and (iii) should help in most situations. If the interference level is still too great disable the interfering transmitter.

Fault location is an extremely useful measurement in the maintenance of RF/microwave links but as with all measurements care is needed to ensure the required accuracy is achieved. If in doubt the best option is always to contact the test equipment manufacturer.

Table 1

Return Loss (dB)	VSWR	Voltage Reflection Coefficient Γ
1	17.3906	0.89125
2	8.72423	0.79433
3	5.84804	0.70795
4	4.441943	0.63096
5	3.56977	0.56234
6	3.00952	0.50119
7	2.61457	0.44668
8	2.32285	0.39811
9	2.09988	0.35481
10	1.92495	0.31623
11	1.78489	0.28184
12	1.67090	0.25119
13	1.57689	0.22387
14	1.49852	0.19953
15	1.43258	0.17783
16	1.37668	0.15849
17	1.32898	0.14125
18	1.28805	0.12589
19	1.25276	0.11220
20	1.22222	0.10000
21	1.19569	0.08913
22	1.17257	0.07943
23	1.15238	0.07079
24	1.13469	0.06310
25	1.11917	0.05623
26	1.10553	0.05012
27	1.09351	0.04467
28	1.08292	0.03981
29	1.07357	0.03548
30	1.06531	0.03162
31	1.05800	0.02818
32	1.05153	0.02512
33	1.04580	0.02239
34	1.04072	0.01995
35	1.03621	0.01778
36	1.03221	0.01585
37	1.02866	0.01413
38	1.02550	0.01259
39	1.02270	0.01122
40	1.02020	0.01000

For the very latest specifications visit www.aeroflex.com

CHINA Beijing

Tel: [+86] (10) 6467 2716
Fax: [+86] (10) 6467 2821

CHINA Shanghai

Tel: [+86] (21) 6282 8001
Fax: [+86] (21) 62828 8002

FINLAND

Tel: [+358] (9) 2709 5541
Fax: [+358] (9) 804 2441

FRANCE

Tel: [+33] 1 60 79 96 00
Fax: [+33] 1 60 77 69 22

GERMANY

Tel: [+49] 8131 2926-0
Fax: [+49] 8131 2926-130

HONG KONG

Tel: [+852] 2832 7988
Fax: [+852] 2834 5364

INDIA

Tel: [+91] 80 5115 4501
Fax: [+91] 80 5115 4502

KOREA

Tel: [+82] (2) 3424 2719
Fax: [+82] (2) 3424 8620

SCANDINAVIA

Tel: [+45] 9614 0045
Fax: [+45] 9614 0047

SPAIN

Tel: [+34] (91) 640 11 34
Fax: [+34] (91) 640 06 40

UK Burnham

Tel: [+44] (0) 1628 604455
Fax: [+44] (0) 1628 662017

UK Stevenage

Tel: [+44] (0) 1438 742200
Fax: [+44] (0) 1438 727601
Freephone: 0800 282388

USA

Tel: [+1] (316) 522 4981
Fax: [+1] (316) 522 1360
Toll Free: 800 835 2352

As we are always seeking to improve our products, the information in this document gives only a general indication of the product capacity, performance and suitability, none of which shall form part of any contract. We reserve the right to make design changes without notice. All trademarks are acknowledged. Parent company Aeroflex, Inc. ©Aeroflex 2005.

www.aeroflex.com
info-test@aeroflex.com



Our passion for performance is defined by three attributes represented by these three icons: solution-minded, performance-driven and customer-focused.

Part No. 46891/869, Issue 2, 08/05