

Application Note



Bluetooth test capability on 2026B



The integration of Bluetooth interfaces into cellular mobile products brings new challenging test issues in the design and manufacture stages.

This application note outlines the key aspects of RF compatibility and demonstrates the flexibility of 2026B Bluetooth/GSM Option 117 solutions.

What is Bluetooth?

The Bluetooth system is a wireless communication system operating in the 2.4 GHz ISM band intended to provide wireless connectivity over relatively short distances between electronic devices. It can be operated as a small wireless or radio local area network (WLAN or RLAN) or as a point to point communication system. It is likely that Bluetooth interfaces will become common on mobile phones, printers, computers and PDA's, allowing these devices to communicate and exchange information without the need for a wired connection. Commercial opportunities are also being looked at for point of sale terminals and even for vending machines. It is expected that the number of Bluetooth devices will be measured in the billions in a relatively short length of time. The interface has to be cheap to produce and needs to work in office, home and mobile environments with true interoperability between different vendors' products.

The frequency band used by Bluetooth interfaces is shared with other systems. As the frequencies used are un-licensed the presence of these systems is unpredictable. Examples of co-existing systems include microwave ovens, the RF leakage of which can affect Bluetooth performance, and IEEE 802 WLAN systems. The Bluetooth system needs to operate reliably in the presence of these signals. It is more likely to be an interference limited communication system than a sensitivity limited system - especially as the number of systems deployed increases.

When used as part of a mobile phone the Bluetooth interface needs to operate reliably while either the transmitter or receiver of the phone is operating, and avoid causing interference with the operation of the mobile. For GSM mobiles this is a relatively new requirement - the transmitter and receiver of a GSM phone are not required to operate at the same time and this minimizes the risk of self-blocking.

Modulation scheme aspects

The modulation scheme for Bluetooth is relatively simple - it is an FSK system where the data stream is filtered by a Gaussian filter whose 3 dB frequency is 0.5 times the data rate.

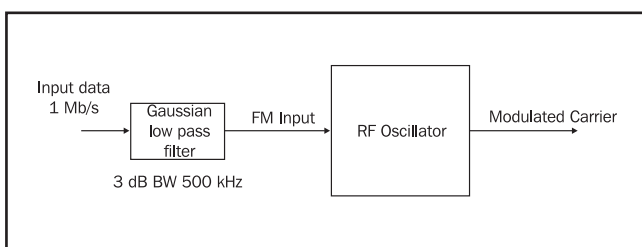

Figure 1 - Bluetooth modulation scheme

Bluetooth signals can be generated from any signal generator with a wide enough FM bandwidth (approximately 1 MHz) and the right frequency range (up to 2.5 GHz). The IFR 2031 and IFR 2026B, for instance, can do so.

The modulation scheme uses TDD (Time Domain Duplex) access techniques. In this scheme the transmit and the receive frequencies are the same, but occur at different times. The carrier frequency is also frequency hopped across the permitted frequency range to give the receiver systems some immunity to multi-path

and interference problems. The permitted frequency band is between 2.4 GHz and 2.4835 GHz, but availability is dependent on which country the user is in. Up to 79 channels are available in some countries and as few as 22 in others. There are also issues related to different band edge guard bands required to protect the adjacent systems. This leads to potential compatibility problems since products defined for use in countries with narrow availability may operate correctly with those designed for the full frequency allocation.

Generating Bluetooth signals with 2026B

The 2026B multi-source signal generator is available with Option 117. Option 117 allows the generation of three carriers, 2 having Bluetooth modulation and one having GSM characteristics.

The 2026B can be fitted with either two or three signal sources that can be combined together on to a common combiner output, or routed to individual outputs. Each of the signal sources can be frequency and amplitude coupled together so that common measurements, such as intermodulation or receiver selectivity, can be performed more quickly and more accurately than using individual signal generators since the sources work together to maintain the required test conditions.

Benefits of the 2026B Option 117 Bluetooth implementation include:

- Integrated source of two Bluetooth carriers to perform inter-modulation, selectivity and blocking tests
- A facility for combining the 2026B signals with those of a Bluetooth test set (or PC mounted interfaces) to simplify design validation and quality checks on receivers and transmitters
- Provision of a GSM modulated carrier for Bluetooth receiver testing in the presence of a GSM air interface
- Internal PRBS or external user supplied data for the Bluetooth signals
- Internal PRBS or external user supplied data for GSM signal

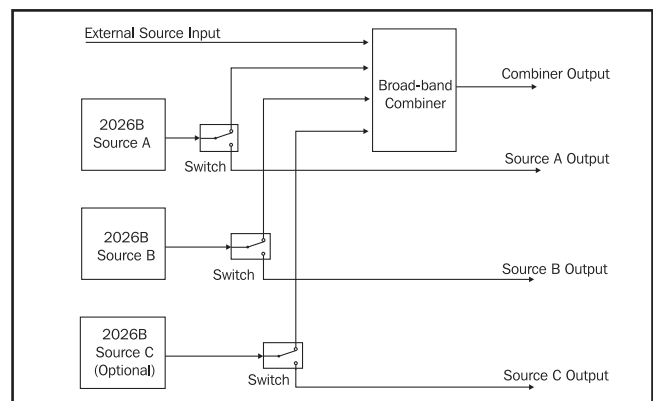

Figure 2 - 2026B block diagram

The 2026B also supports another instrument being connected to the combiner. This source can either be a signal generator or a radio test set. If a radio test set is used it can keep the mobile phone in conversation since the combiner input and output paths are bi-directional, so the radio test set can demodulate the trans-

mitter of the mobile phone while it is exciting the receiver of the device under test.

Option 117 provides base-band data sources, either from an internal PRBS sequence generator or from an external source, which are filtered by a good approximation to a Gaussian filter using analog components. The use of analog components to implement the filter means that there is no complex clocking mechanism required to use an external data source - it simply requires logic level signals for both the GSM and Bluetooth channels.

The resulting base-band signals can then be connected to the external FM input of a 2026B multi-source signal generator to generate a modulated RF carrier signal.

The frequency synthesis scheme, a fractional N system, and the DC FM system (both subject of Aeroflex patents) used in the 2026 provide a high accuracy, low drift, FM port which has sufficient band-width to allow Bluetooth signals to be faithfully reproduced. The GSM base-band system is very similar to that used in 2026 Option 116 that allows the signal generator to provide 3 GSM carriers.

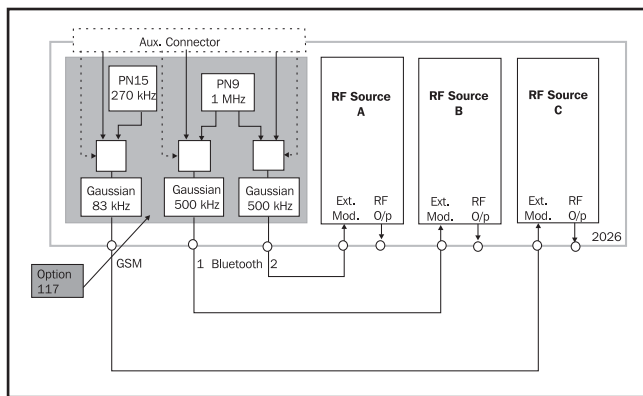

Figure 3 - Implementing Option 117 on 2026B

The PN source for the Bluetooth signal is common to both RF channels but they are separated in time to ensure that the two signals do not correlate. This is important in two signal testing since in real life conditions the Bluetooth carriers will not carry the same information, or necessarily be synchronized to each other.

Testing

Since Bluetooth is a two-way device the logical choice of test device would seem to be a radio test set. However, this may not be practical for a number of reasons. The primary one is cost - a Bluetooth test procedure based on a test set is likely to be an expensive solution compared to the cost of the interface. Bluetooth is inherently a low cost technology and testing it with a test set costing \$30 k or more makes little sense. A specialized test set only makes sense in a conformance test environment or early manufacturing when technical difficulties are more likely to be encountered.

A second issue is what is actually going to be tested. The design of the Bluetooth part is likely to be highly integrated with its host device, and often no direct RF connection will be supplied (as on

some mobile phones the antenna could be integrated into the host). Any test therefore relies on a coupler of some description - and doing "traceable" measurements of sensitivity is difficult in these circumstances.

The high levels of integration possible with Bluetooth also mean that in reality the primary objective is to prove that the chip set has been correctly assembled. The actual performance is determined by a few devices, which should have been adequately tested as components. Testing should be focussed on ensuring that the parts have been correctly placed and that they function adequately in the environment in which they operate. The test scenario should concentrate on functional go/no-go testing and checking that the Bluetooth and GSM systems do not mutually interfere.

Besides the obvious route of testing with a radio test set, there are some simple ways of testing Bluetooth interfaces.

- Manufacturing test can be done with a commercial Bluetooth device in a PC or similar host. If the PC that controls the test system is relatively remote from the UUT then look towards placing a simpler device nearer the UUT (e.g. a PDA) or use the RF output (antenna connection) to connect the Bluetooth signal to an antenna nearer the test system. Basically keep it simple. The use of an antenna driven by a PC hosted Bluetooth interface offers a simple solution since it also offers a simple route to the parametric tests below. Adding some attenuation in the path would reduce the transmitted power and exercise the Bluetooth device harder, as well as limit the chances of test systems interacting. The value of attenuation needs to be considered carefully since it effects both the transmitter and receiver paths.
- A parametric risk may be that the Bluetooth transmitter blocks the cellular receiver. Mechanical assembly imperfections or poor grounding of components can affect screening and filtering, which in turn leads to performance degradation. This can be tested using a 2026B to inject interfering signals when testing the cellular receiver.
- A second parametric risk is that the cellular device transmitter blocks the Bluetooth receiver. Using a 2026 to inject signals at cellular frequencies can test the receiver.

These parametric tests could be on every device, or if yield is high and defects are batch related, they could be QA tests.

The Bluetooth receiver test is probably the least critical since it is the least demanding air interface. Self-blocking of the cellular interface would cause the network to increase the cellular power and hit network capacity. Self-blocking of the Bluetooth receiver would simply cut the useful range of the Bluetooth link.

Figure 4 below shows how the test setup might look. Note that the 2026B could be a single unit, which is switched into either path, but that would increase RF complexity significantly and cause problems in holding the phone in conversation while the Bluetooth interface was active.

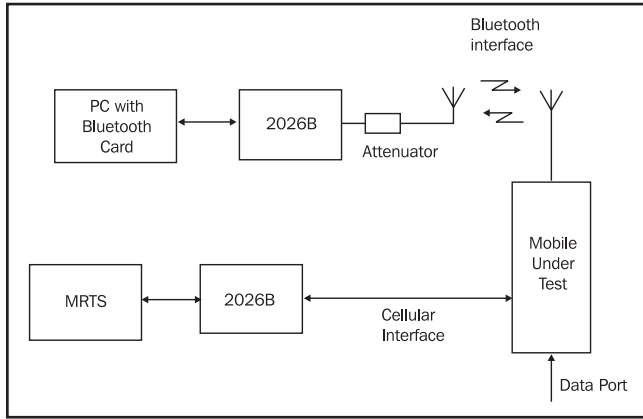

Figure 4 - Using 2026B to aid testing the Bluetooth and GSM air interfaces

At the Bluetooth interface the 2026B provides a through connection for the Bluetooth interface hosted (or connected) to the PC. The attenuators are used to reduce the signal level of the Bluetooth interface (for both the transmitters and the receivers) so the receivers see a more representative test level. The 2026B can then put up two Bluetooth and a GSM interfering signal.

In a similar way at the cellular interface the 2026B provides a through connection to the mobile so it can be held in conversation by the test set. The 2026B can then add Bluetooth, CW or GSM modulated interfering signals.

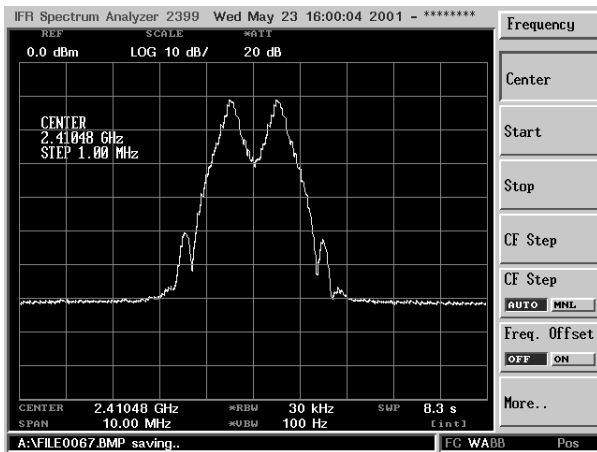

Figure 5 - Two Bluetooth IFR 2026B Opt. 117 signals on adjacent channels

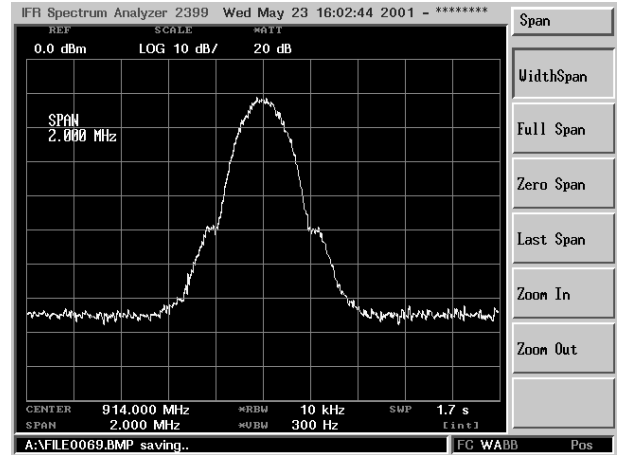

Figure 6 - 2026B Opt. 117 GSM signal emulation

For both interfaces the 2026B can add the signals which enable accurate measurements of the ability of the receiver to reject interfering signals.

In each case the GSM and Bluetooth signals are required to have pseudo-random characteristics - no specific data patterns are required.

Both the GSM and the Bluetooth systems support a loop back facility where the receiver can be forced to loop the demodulated signal back to the transmitter. In this way the device performing the testing can send a data string to the UUT, which will then return the same data to the tester. In this way a BER (bit error rate) test can be performed to test the ability of the receiver to correctly decode the information (assuming the transmitter is working correctly) while the 2026B is adding the interfering signals.

The Bluetooth specifications also simplify some tests by specifying modes of operation (for testing) where the output frequency is not hopping, and a reduced hopping mode where only five hop frequencies are used.

The specification includes requirements for co-channel interference (where the wanted signal is overlaid by an interfering Bluetooth signal on the same frequency) and out of channel blocking with a CW signal. The intermodulation test requires the generation of a Bluetooth signal and a CW signal. The 2026B can conveniently supply all of these signals.

External Data Input

In addition to the PN sequences the 2026B can also accept data from an external data source on a rear panel connector. The same connector is used to provide the FSK inputs for 2026B.

Pin Number	Function
20	Data input for A source.
21	Data select for A. Low for external.
22	Data input for B.
23	Data select for B. Low for external.
24	Data input for C source.
25	Data select for C. Low for external.
13	Ground.

Figure 7 - A D type connector on the rear panel of 2026B provides the data selection and data inputs for Option 117. The selection lines have internal pull up resistors.

Each of the three base-band sources can accept external data from simple logic interfaces. The 2026B converts these signals into controlled level signals that are used to drive the filters and provide the required analog drive signals for the 2026B FM system.

For Bluetooth signals the method of generating the modulation is exactly as described in the standard - a filtered FSK system. In reality the 2026 synthesizer and DC FM system used to produce the signals is of a much better quality than are available in real systems. The 2026B allows the user to vary the FM deviation of the Bluetooth signal over a wide range to demonstrate the effect of deviation on sensitivity and any interference impact it might have.

Setting the FM system

The Bluetooth specification states the "modulation index" of the signal has to be between 0.28 and 0.35, interpreted as corresponding to a peak to peak deviation of 280 kHz to 350 kHz (mean value 315 kHz peak to peak). In use the 2026B external FM should be set to 157 kHz, external FM mode, with the modulation ALC off. To generate a Bluetooth modulated carrier the 2026B needs a wide external FM input bandwidth and since the FM bandwidth is wider when the modulation ALC is switched off, this mode must be used.

For the GSM system the use of FM techniques limits the accuracy of the GSM signal generated. For GSM modulation the FM deviation is set to 67.7 kHz (external FM mode). For GSM the modulation ALC can be enabled since the required bandwidth is much lower. Errors in the FM deviation accuracy will result in errors in the accumulated phase error if long strings of 1's or 0's are transmitted. However, these signals are unlikely to occur in real systems since coding schemes deliberately try to remove any such structures from the signal. Consequently the 2026B modulated carrier is a good representation of a continuous GSM carrier. More information on the use of the GSM carrier can be found in application notes on 2026 Option 116.

Summary

The 2026B Option 117 provides a useful tool for designers of cellular and Bluetooth devices to test receiver systems for sensitivity and blocking characteristics. The 2026B can be used in demanding manufacturing applications, whether it is for routine manufacture in the early phase of deployment or as part of a quality control test system monitoring the output of volume devices using the Bluetooth interface.

More information on Bluetooth can be obtained from the web site www.bluetooth.com. Details of the Bluetooth test specification have been avoided in this application note since at the time of writing the specifications are still subject to change.

Option 117 Bluetooth and GSM Modulation

Available on 2026B fitted with Option 1.

Provides 2 baseband sources for generating Bluetooth carriers.

Provides a baseband source for generating a GSM carrier.

Bluetooth Sources

Data Source	Internal or external on a D Type connector. Source selection lines are on the rear apron Auxiliary Port connector. Internal source is (29-1) PRBS sequence
Internal Data Rate	1 MHz
Internal Data Rate	As frequency standard
Accuracy	
Filter	Bt 0.5 (500 kHz) Gaussian filter, approximated by 8 pole RC filter
FM Accuracy	Typically better than 7% (Mod ALC off, PRBS source)

GSM Source

Data Source	Internal or external on a D Type connector. Source selection lines are on the rear apron Auxiliary Port connector. Internal source is (215-1) PRBS sequence
Internal Data rate	270.8333333 kHz (13 MHz/48)
Internal Data Rate	As frequency standard
Accuracy	
Filter	Bt 0.3 Gaussian filter approximated by 8 pole RC filter
FM accuracy	Typically better than 2% (Mod ALC on, PRBS source)

For the very latest specifications visit www.aeroflex.com

CHINA Beijing

Tel: [+86] (10) 6467 2716
Fax: [+86] (10) 6467 2821

CHINA Shanghai

Tel: [+86] (21) 6282 8001
Fax: [+86] (21) 62828 8002

FINLAND

Tel: [+358] (9) 2709 5541
Fax: [+358] (9) 804 2441

FRANCE

Tel: [+33] 1 60 79 96 00
Fax: [+33] 1 60 77 69 22

GERMANY

Tel: [+49] 8131 2926-0
Fax: [+49] 8131 2926-130

HONG KONG

Tel: [+852] 2832 7988
Fax: [+852] 2834 5364

INDIA

Tel: [+91] 80 5115 4501
Fax: [+91] 80 5115 4502

KOREA

Tel: [+82] (2) 3424 2719
Fax: [+82] (2) 3424 8620

SCANDINAVIA

Tel: [+45] 9614 0045
Fax: [+45] 9614 0047

SPAIN

Tel: [+34] (91) 640 11 34
Fax: [+34] (91) 640 06 40

UK Burnham

Tel: [+44] (0) 1628 604455
Fax: [+44] (0) 1628 662017

UK Stevenage

Tel: [+44] (0) 1438 742200
Fax: [+44] (0) 1438 727601
Freephone: 0800 282388

USA

Tel: [+1] (316) 522 4981
Fax: [+1] (316) 522 1360
Toll Free: 800 835 2352

As we are always seeking to improve our products, the information in this document gives only a general indication of the product capacity, performance and suitability, none of which shall form part of any contract. We reserve the right to make design changes without notice. All trademarks are acknowledged. Parent company Aeroflex, Inc. ©Aeroflex 2005.

www.aeroflex.com
info-test@aeroflex.com



Our passion for performance is defined by three attributes represented by these three icons: solution-minded, performance-driven and customer-focused.

Part No. 46891/892, Issue 3, 06/04